

SBACH 342

USER MANUAL



Warning: This aircraft is a hobby grade product,
only for people 14-year old or above.

Before operating this unit, please read these instructions completely.

Examine your kit carefully!

Our model kits are subject to constant quality checks throughout the production process, and we sincerely hope that you are completely satisfied with the contents of your kit. However, we would ask you to check all the parts before you start construction, referring to the Parts List, as we cannot exchange components which you have already modified. If you find any part is not acceptable for any reason, we will readily correct or exchange it once we have examined the faulty component. Just send the offending part to our Model Department. Please be sure to include the enclosed complaint form, duly completed. We are constantly working on improving our models, and for this reason we must reserve the right to change the kit contents in terms of shape or dimensions of parts, technology, materials and fittings, without prior notification. Please understand that we cannot entertain claims against us if the kit contents do not agree in every respect with the instructions and the illustrations.

Caution!

Radio-controlled models, and especially model aircraft, are by no means playthings in the usual sense of the term. Building and operating them safely requires a certain level of technical competence and manual skill, together with discipline and a responsible attitude at the flying field. Errors and carelessness in building and flying the model can result in serious personal injury and damage to property. Since we, as manufacturers, have no control over the construction, maintenance and operation of our products, we are obliged to take this opportunity to point out these hazards and to emphasise your personal responsibility.

- Specifications
- Steps of assembly
- Choose a flying field
- Center of gravity
- Safety

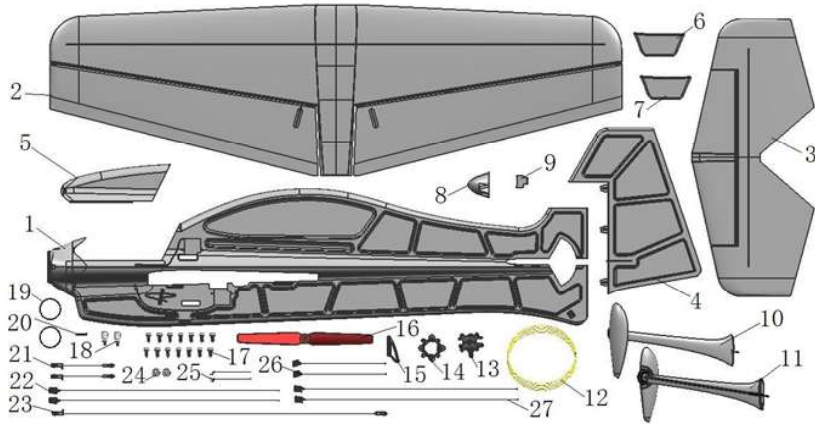

- | | | | |
|--------------------------------|-----|--------------------------------|-------|
| 1. Fuselage | 1pc | 15. Aileron servo control horn | 1pc |
| 2. Wing | 1pc | 16. GWS HD 8040 | 1pc |
| 3. Elevator | 1pc | 17. Screw (ST1.4*6) | 14pcs |
| 4. Rudder | 1pc | 18. Adjustor | 2pcs |
| 5. Equipment canopy | 1pc | 19. O ring | 2pcs |
| 6. Right wing fence | 1pc | 20. Spinner connecting part | 1pc |
| 7. Left wing fence | 1pc | 21. Aileron push rod | 2pcs |
| 8. Spinner | 1pc | 22. Wing bracings #1 | 2pcs |
| 9. Fuselage foam block | 1pc | 23. Elevator push rod | 1pc |
| 10. Left part of landing gear | 1pc | 24. Washers | 2pcs |
| 11. Right part of landing gear | 1pc | 25. Vector system push rod | 2pcs |
| 12. Pull-pull fishing line | 1pc | 26. Elevator bracings | 2pcs |
| 13. Vector system | 1pc | 27. Wing bracings #2 | 2pcs |
| 14. Motor mount | 1pc | | |

Features

1. Matched with vector rotating system on rudder which increases the flexibility on rudder control.
2. Good wind-resistance and stability, easy for control.
3. EPO foam construction that is beautiful, crash-resistant and easy for maintenance makes very robust airframe.
4. A thoughtful equipment cabin design, all electronic equipments can be installed and safely secured inside.
5. Simple design, 85% pre-assembled and super convenient assembly process keeps you far away from the complicated traditional assembly process of indoor 3D plane and long time waiting.
6. Professional airframe configuration and special airfoil design makes it a great lightweight 3D airplane for a wide flight speed range.
7. No matter you're professional 3D flyer or just starting out in 3D, we believe Sbach342 is a good choice.

Specifications

| SBACH342 | PNP | KIT+MOTOR |
|-----------------------------------|--------------------|--------------------|
| Motor AT2206V2 KV 1500 | Installed | Installed |
| ESC 10A With BEC | Installed | Needed to complete |
| Servos 8g servo | Installed | Needed to complete |
| Battery 3S 400mAh 20C Li-Po | Needed to complete | Needed to complete |
| Li-Po Charger | Needed to complete | Needed to complete |
| Receiver | Needed to complete | Needed to complete |
| Transmitter | Needed to complete | Needed to complete |

| SBACH342 Specification | |
|------------------------|-----------------------------|
| Wingspan | 33.1 in (840 mm) |
| Length | 37.8 in (960 mm) |
| Weight (with battery) | 0.61 lb-0.65 lb (275g-295g) |
| Propeller: | SF8040 prop |

Steps of ASSEMBLY

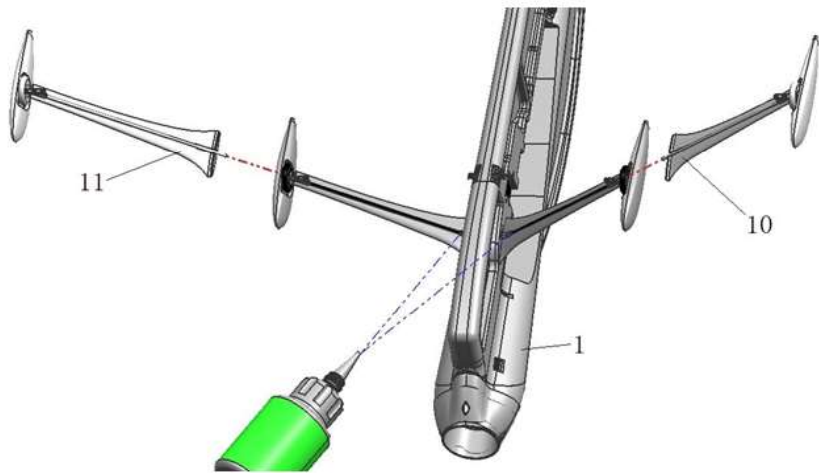

1. Install left and right landing gear into corresponding slots on fuselage, then fix with glue.

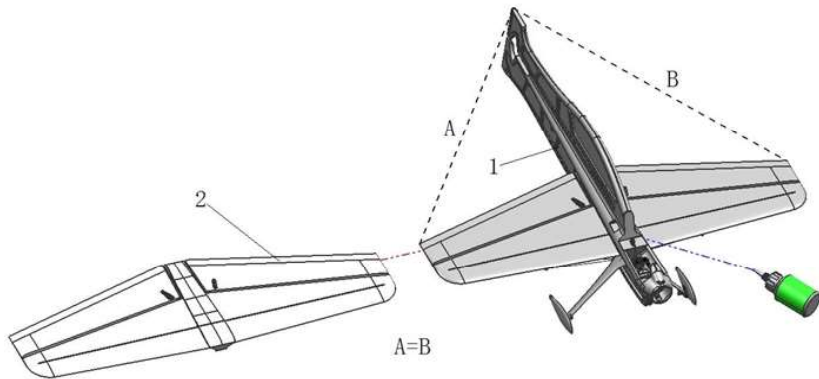

2. Insert wing into corresponding slots on fuselage, then use glue to fix. Make sure the wing without installed control horn pass through fuselage first, and ensure the wing is perpendicular to fuselage. A=B.

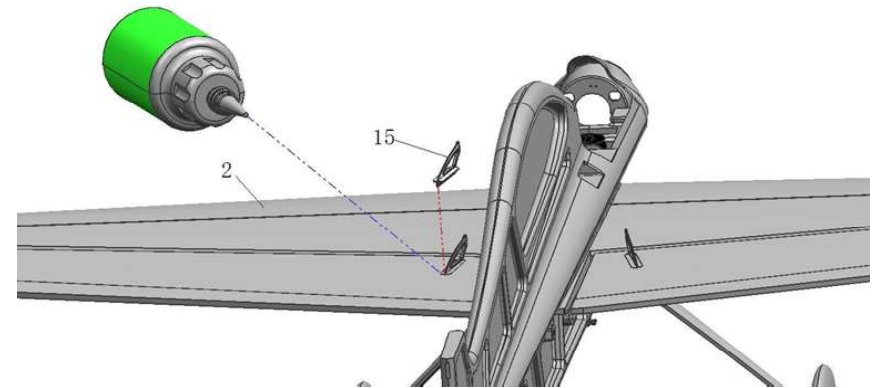

3. Install aileron servo control horn into corresponding slot on aileron, then fix with glue.

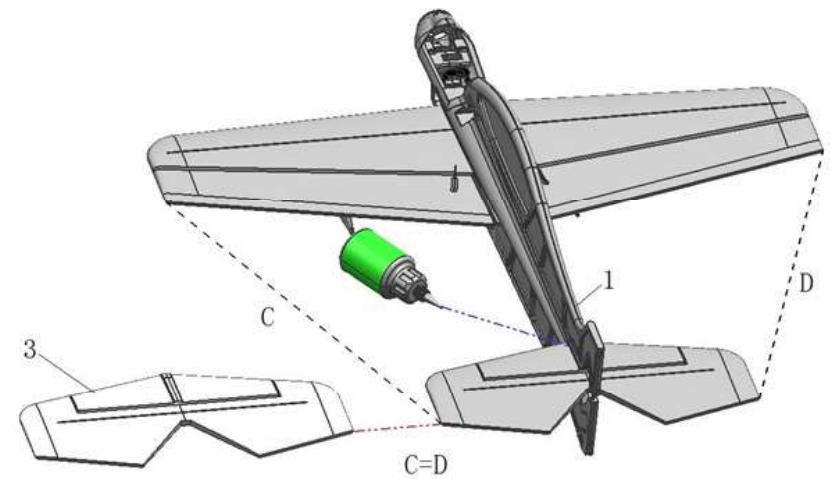

4. Insert stabilizer into the slot of rear fuselage and fix with glue. Make sure C=D.

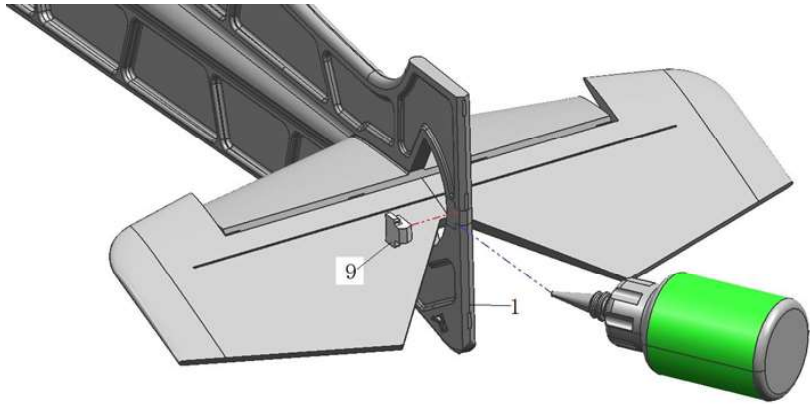

5. Install fuselage foam block into slot that shown in above picture, then fix with glue.

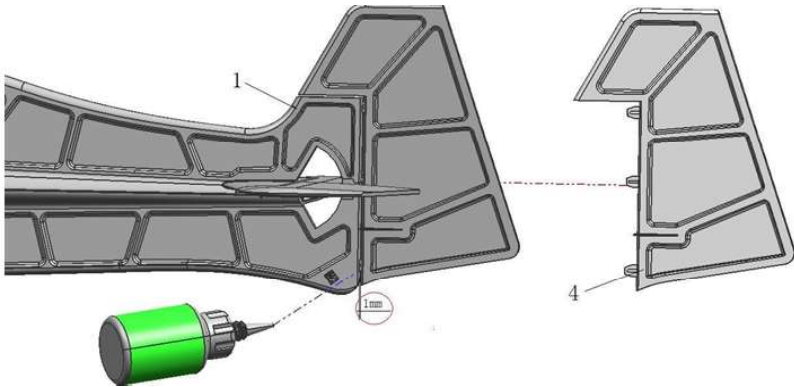

6. Attach rudder onto the rear fuselage according to their corresponding cuttings and fix with glue. Make sure the rudder is on the same level as fuselage.

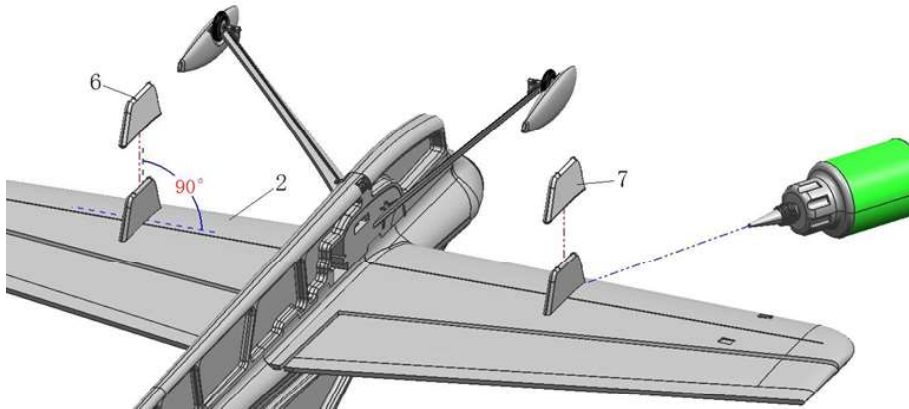

7. Insert left and right wing fences into slots on wing, make sure they're perpendicular to wing, then fix with glue.

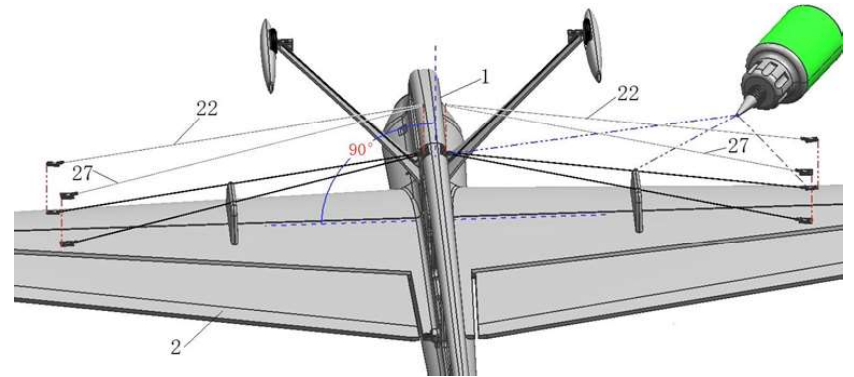

8. Install wing bracing rod 1 and 2 on corresponding places on wing and fuselage, after make sure wing and fuselage is perpendicular to each other, fix the bracings with glue.

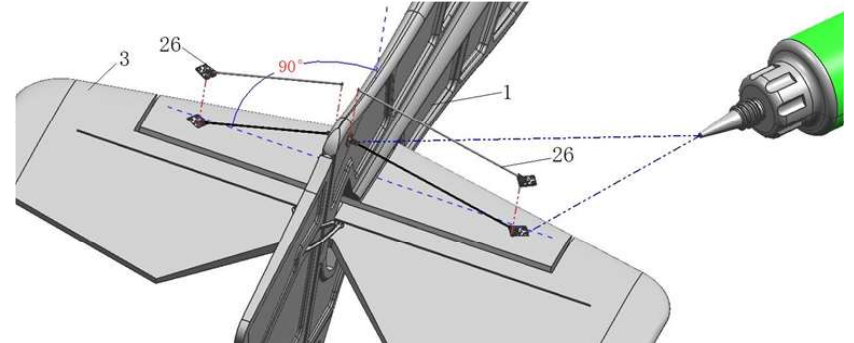

9. Install elevator bracings as picture shown. Make sure fuselage and elevator is perpendicular to each other, then fix the bracings with glue.

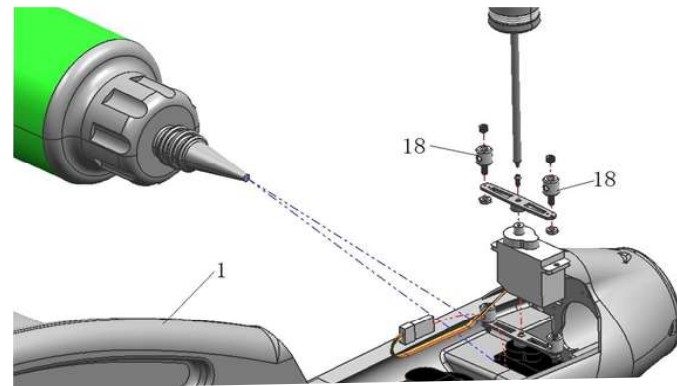

9.1. Place adjusters into holes on servo arm, and fix them with nuts both upside and downside. Befor adding glue on joints between servo arm and nuts, make sure adjusters are in function.
 9.2. Pass the servo wires through the servo house as picture shown.
 9.3. Fix the assembled servo arm onto servo with screw.
 9.4. Put this servo which will be used for vector system into the servo house, then fix with glue.

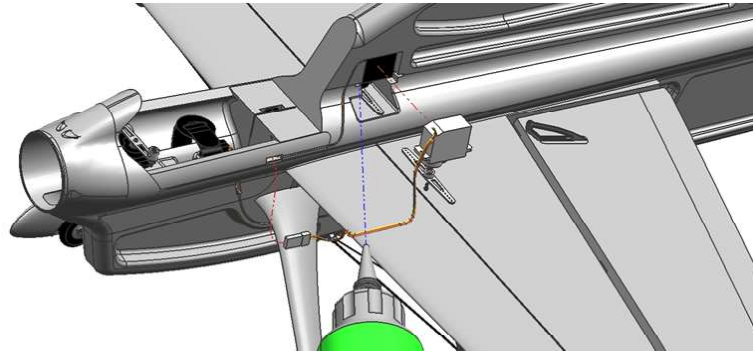

- 10.1. Pass aileron servo wires through corresponding servo house.
- 10.2. Fix servo arm on servo with screw.
- 10.3. Place aileron servo into corresponding servo house, then fix with glue.

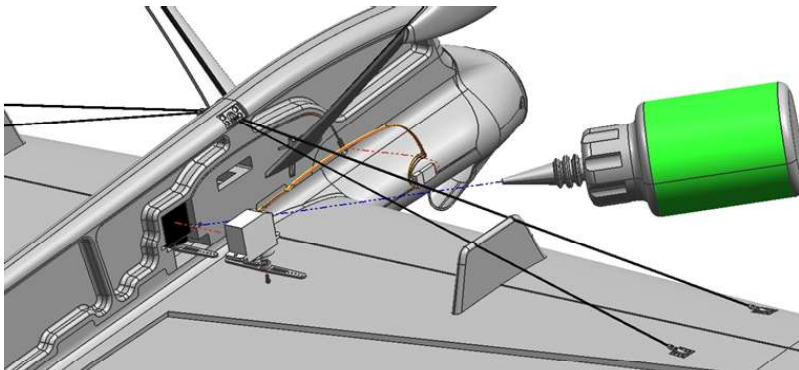

- 11.1. Pass elevator servo wires through corresponding servo house.
- 11.2. Fix servo arm on servo with screw.
- 11.3. Place elevator servo into corresponding servo house, then fix with glue.

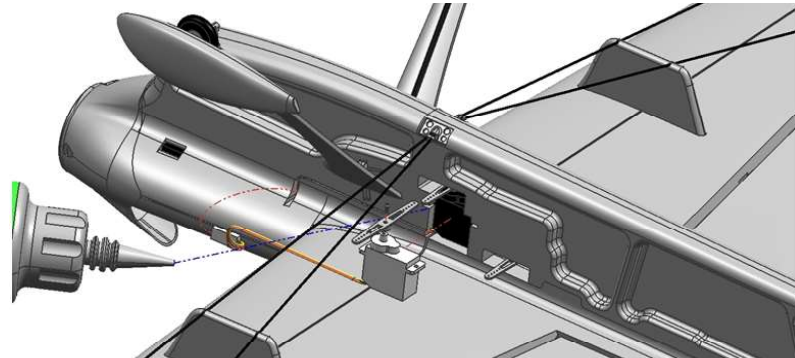

- 12.1. Pass rudder servo wires through corresponding servo house.
- 12.2. Fix servo arm on servo with screw.
- 12.3. Place rudder servo into corresponding servo house, then fix with glue.

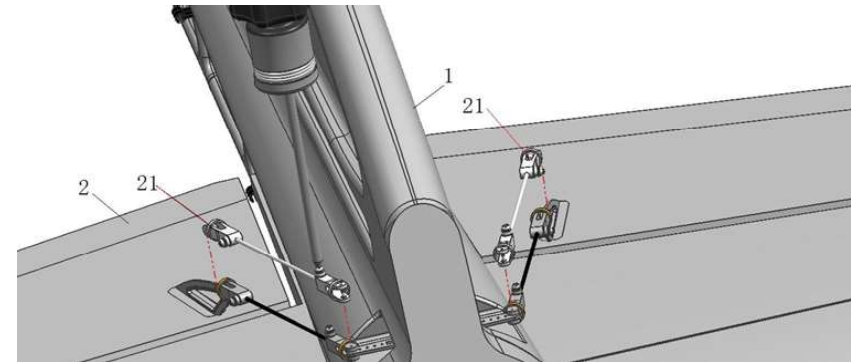

- 13. Install the aileron pushrod, one end connected to aileron control horn, another end connected to servo arm. You can adjust the length of pushrod with clips on the two ends.

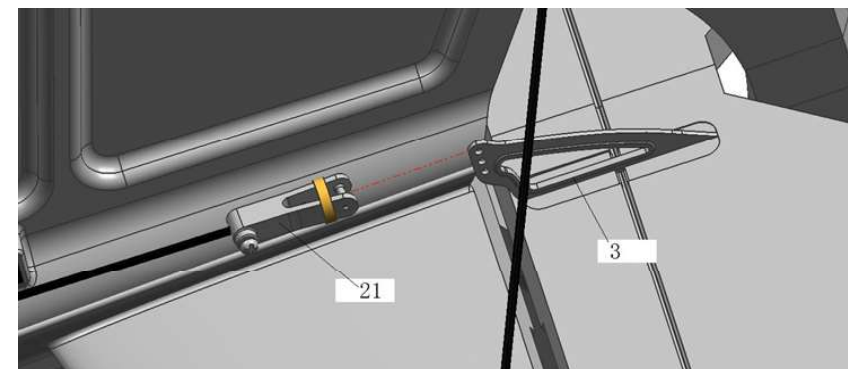
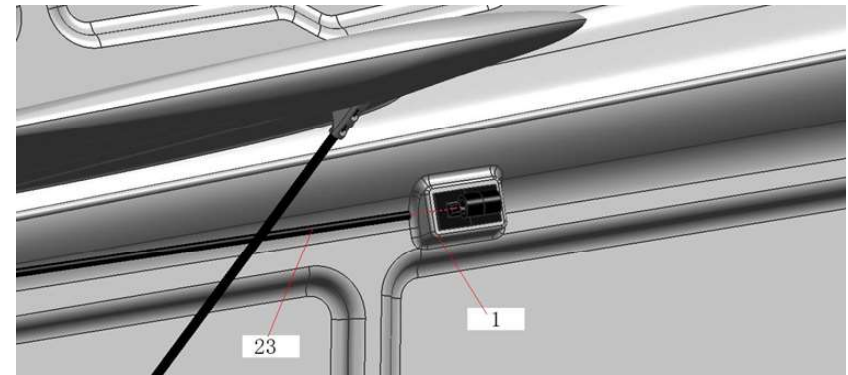

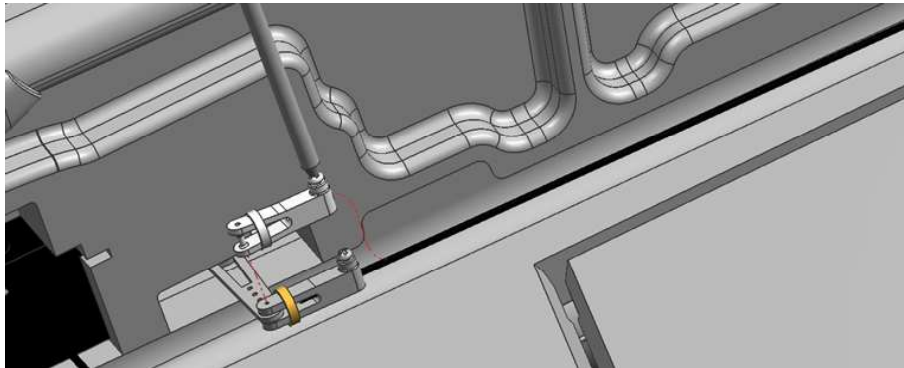

- 14.1. Remove one clip from the elevator pushrod, then pass the pushrod through the pushrod guiding tube.
- 14.2. Put on the removed clip on pushrod.
- 14.3. Install the elevator pushrod, one end connected to control horn, another end connected to servo arm. You can adjust the length of pushrod with clips on the two ends.

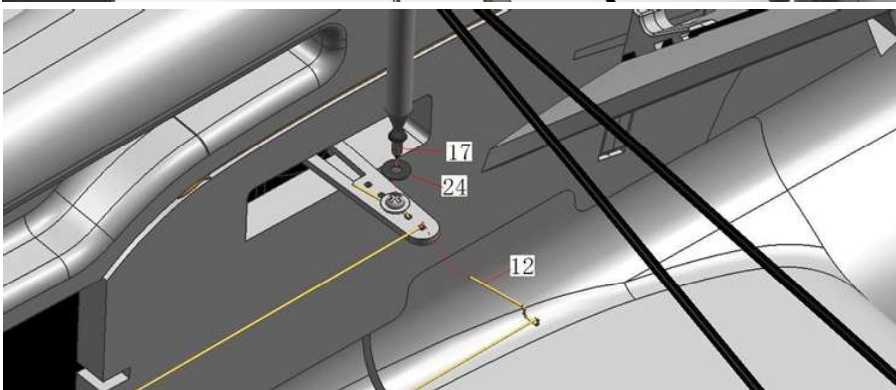
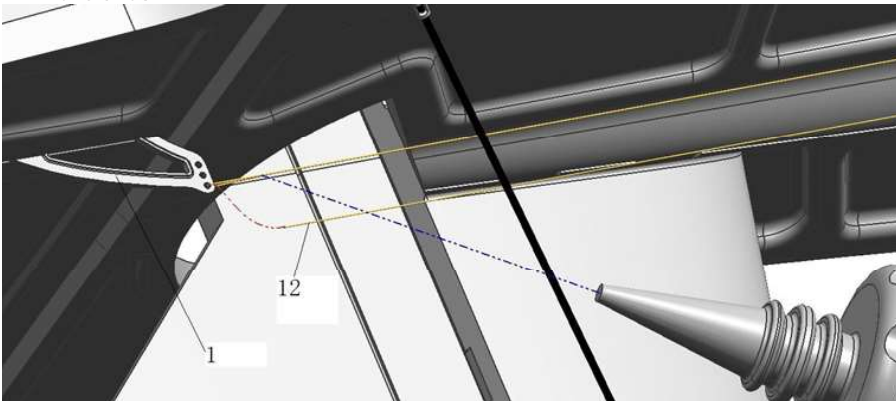

- 15.1. Thread the pull-pull fishing line through the rudder servo hole, then fix it with glue.
- 15.2. Adjust the pull-pull line to a proper length, and pass another end of fishing line through the servo arm, then fix it with screw and washer as picture shown.

16. Vector system installation

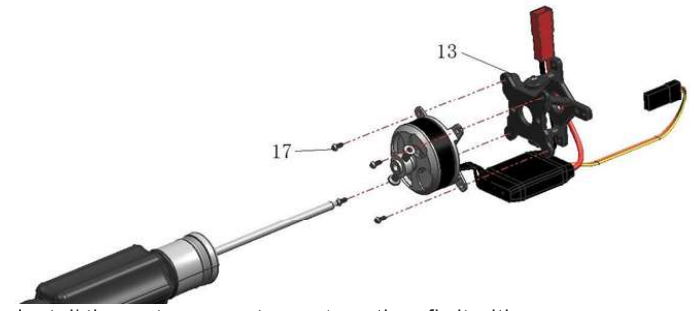

16. 1. Install the motor on vector system, then fix it with screws.

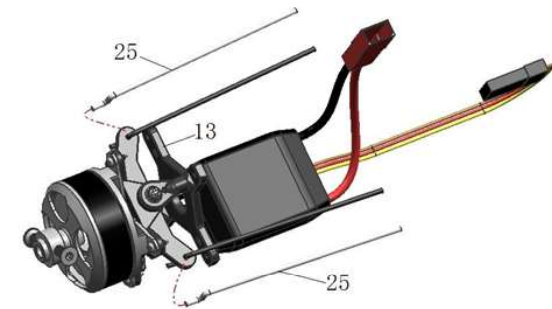

- 16.2. Connect the vector system pushrod with Z bend to the corresponding holes.

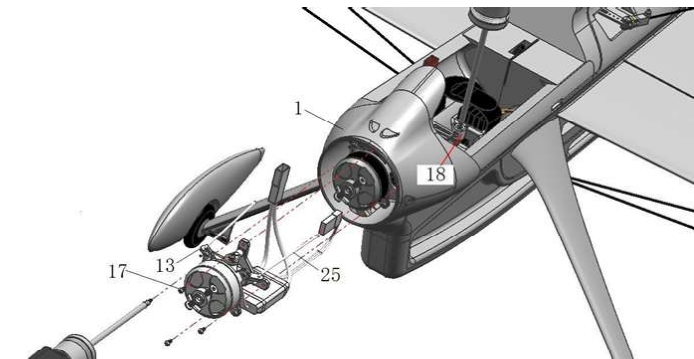

- 16.3. Install vector system on motor mount with screws. And pass the pushrod wire through the hole on adjustor, then adjust the wire length with screw on adjustor.

17. If you don't need the vector system, please read following installation steps.

17.1. Skip step 9 on how to install vector system servo.

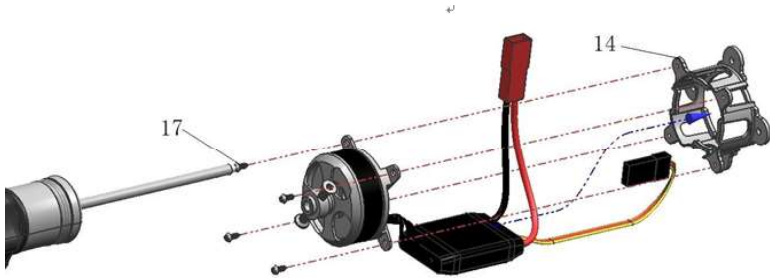

17. 2. Pass ESC through the middle part of motor mount.
17. 3. Install motor on motor mount with screws.

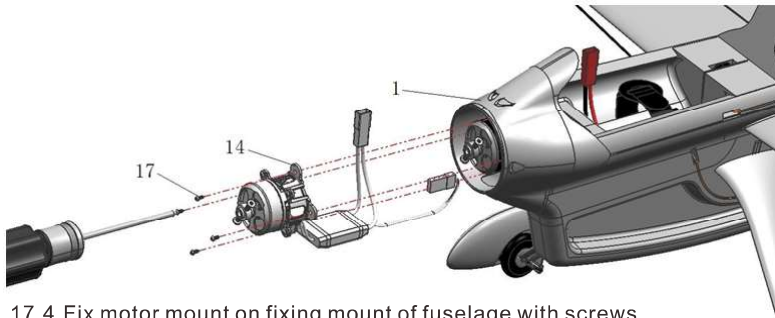

17.4. Fix motor mount on fixing mount of fuselage with screws.

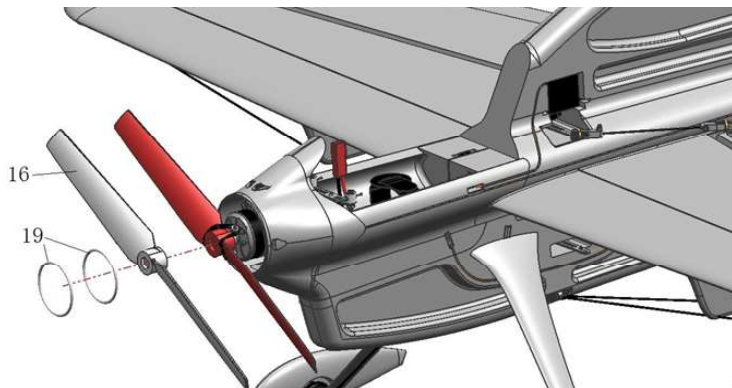

18. Install 8040 propeller on motor with O rings.

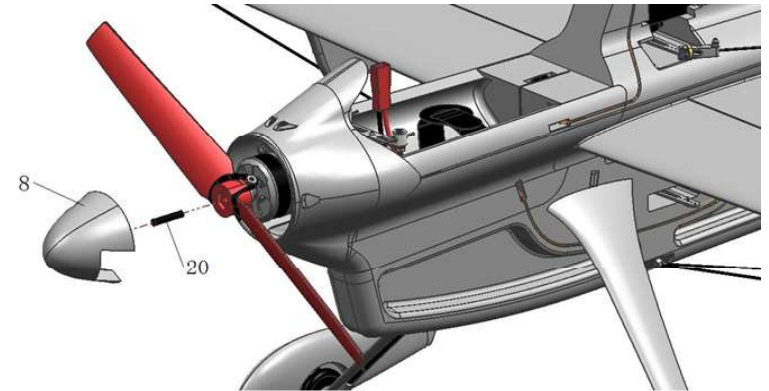

19. 1. Insert spinner connecting part into middle hole of propeller. (no need to drop glue)
19. 2. Another end connect to spinner, then fix with glue.

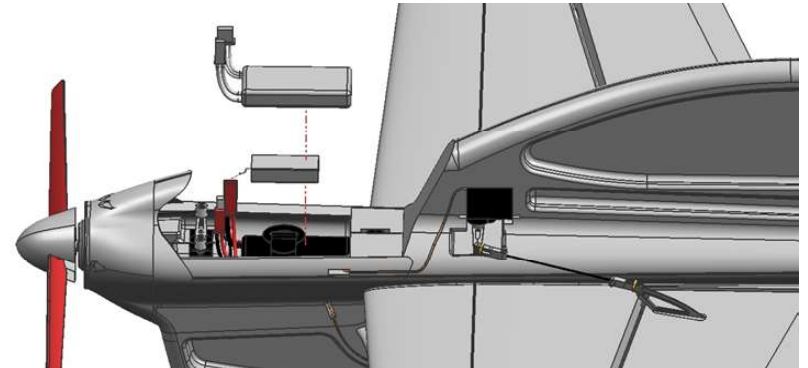

20. Place receiver and battery into equipment cabin, then fix with velcro.

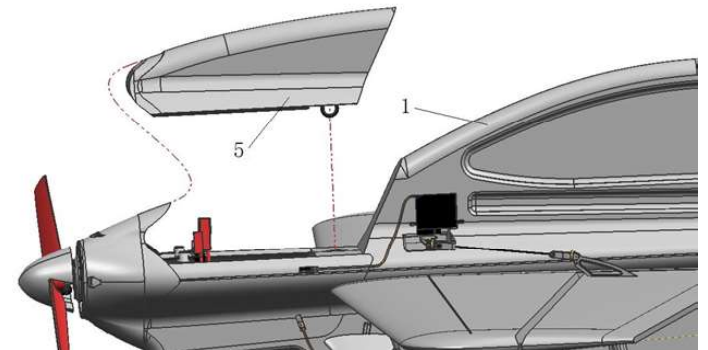

21. Cover the equipment canopy.

Choose a Flying Field

In order to have the most success and to protect your property and aircraft, it is very important to select a place to fly that is very open. Consult local laws and ordinances before choosing a location to fly your aircraft.

The site should:

- Have a minimum of 200m of clear space in all directions.
- Stay clear of pedestrians.
- Stay free of trees, buildings, cars, power lines or anything that could entangle your aircraft or interfere with your line of sight.

Plan on flying in an area that gives you more space than you think you need, especially with first flights.

Center Of Gravity

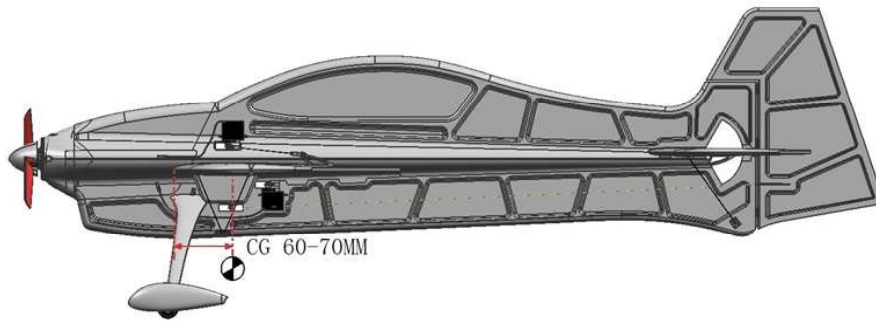

The centre of gravity (CG) should be at a position of 60mm-70mm away from leading edge, please refer to above picture.

Safety

Safety is the First Commandment when flying any model aircraft. Third party insurance should be considered a basic essential. If you join a model club suitable cover will usually be available through the organisation. It is your personal responsibility to ensure that your insurance is adequate. Make it your job to keep your models and your radio control system in perfect order at all times. Check the correct charging procedure for the batteries you are using. Make use of all sensible safety systems and precautions which are advised for your system. An excellent source of practical accessories is our main catalogue, as our products are designed and manufactured exclusively by practising modellers for other practising modellers.

Always fly with a responsible attitude. You may think that flying low over other people's heads is proof of your piloting skill; others know better. The real expert does not need to prove himself in such childish ways. Let other pilots know that this is what you think too.

Always fly in such a way that you do not endanger yourself or others. Bear in mind that even the best RC system in the world is subject to outside interference. No matter how many years of accident-free flying you have under your belt, you have no idea what will happen in the next minute.

We hope you have many hours of pleasure building and flying your new model.

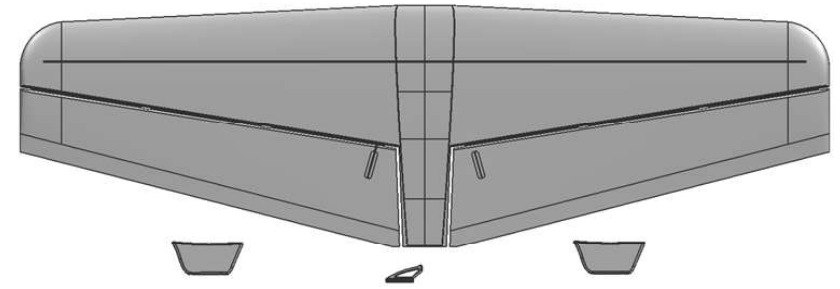

Wing

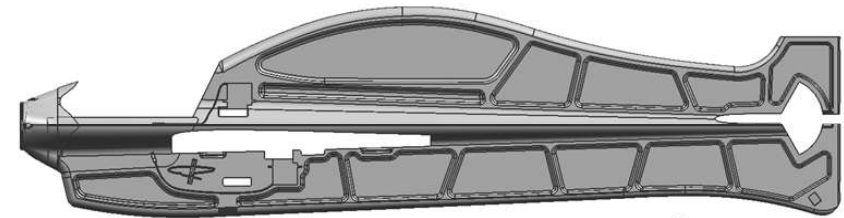

Fuselage

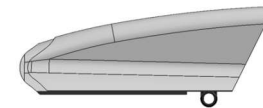

Equipment canopy

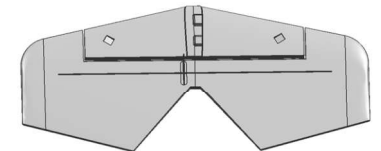

Stabilizer

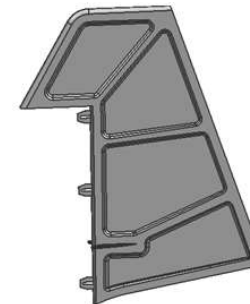

Vertical fin

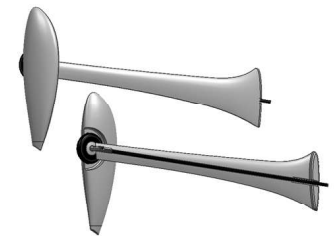

Landing gear set

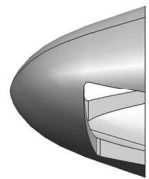

Spinner

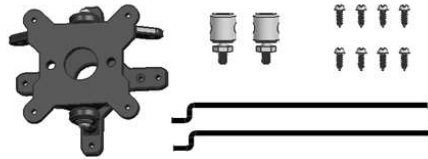

Vector system

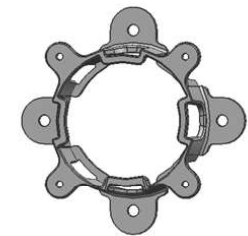

Motor mount

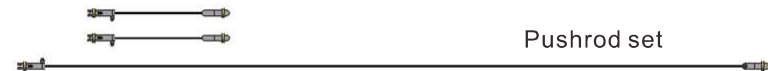

Pushrod set

Bracings

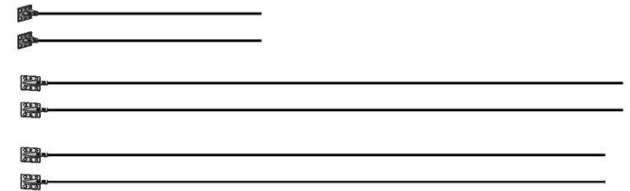

O ring



Other accessory pack

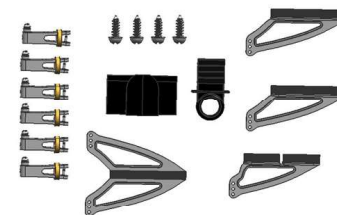

Motor : 2206 Kv1500



Servo: 8g micro servo

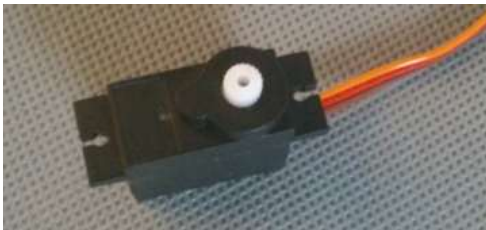

ESC :10Amp



Propeller: 8040 SF prop

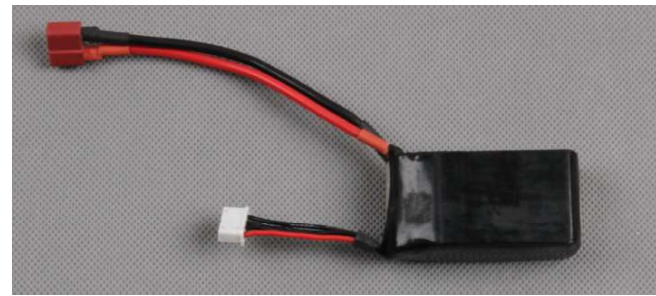

Battery3S 400mAh 20C Li-Po

