

27% **EDGE 540** 3D ARF

1.60 GLOW / 43 cc GAS **PERFORMANCE SERIES™**

INSTRUCTION MANUAL



Wingspan: 78 in [1980mm]
Wing Area: 1088 sq in [70.2 dm²]
Weight: 13-15 lb [5900-6800g]
Wing Loading: 28-32 oz/sq ft [84-97 g/dm²]
Length: 74.5 in [1890mm]
Radio: 4-Channel Minimum, 6-7 Servos
Engine: 1.6-1.8 cu. in. [26-30 cc] two-stroke, 1.8-2.1 cu. in. [30-34 cc] four-stroke,
1.9-2.6 cu. in. [32-43 cc] gas, 63-62-250 RimFire out-runner motor

WARRANTY

Great Planes® Model Manufacturing Co. guarantees this kit to be free from defects in both material and workmanship at the date of purchase. This warranty does not cover any component parts damaged by use or modification. **In no case shall Great Planes' liability exceed the original cost of the purchased kit.** Further, Great Planes reserves the right to change or modify this warranty without notice.

In that Great Planes has no control over the final assembly or material used for final assembly, no liability shall be assumed nor accepted for any damage resulting from the use by the user of the final user-assembled product. By the act of using the user-assembled product, the user accepts all resulting liability.

If the buyer is not prepared to accept the liability associated with the use of this product, the buyer is advised to return

this kit immediately in new and unused condition to the place of purchase.

To make a warranty claim send the defective part or item to Hobby Services at the address below:

Hobby Services
3002 N. Apollo Dr., Suite 1
Champaign, IL 61822 USA

Include a letter stating your name, return shipping address, as much contact information as possible (daytime telephone number, fax number, e-mail address), a detailed description of the problem and a photocopy of the purchase receipt. Upon receipt of the package, the problem will be evaluated as quickly as possible.

READ THROUGH THIS MANUAL BEFORE STARTING CONSTRUCTION. IT CONTAINS IMPORTANT INSTRUCTIONS AND WARNINGS CONCERNING THE ASSEMBLY AND USE OF THIS MODEL.



Champaign, Illinois
(217) 398-8970, Ext 5
airsupport@greatplanes.com

TABLE OF CONTENTS

INTRODUCTION	2
SAFETY PRECAUTIONS	3
DECISIONS YOU MUST MAKE	3
Building Stand	3
Radio Equipment	4
Engine Recommendations	5
Glow Engine Requirements	5
Brushless Motor Requirements	5
Gas Engine Requirements	5
Propeller	6
ADDITIONAL ITEMS REQUIRED	6
Adhesives and Building Supplies	6
Optional Supplies and Tools	6
IMPORTANT BUILDING NOTES	6
ORDERING REPLACEMENT PARTS	7
KIT CONTENTS	8
PREPARATIONS	9
ASSEMBLE THE WING	9
Install the Ailerons	9
Install the Aileron Servos and Pushrods	10
Join the Wing Panels	11
ASSEMBLE THE TAIL SECTION & LANDING GEAR ...	13
Install the Stabilizer, Elevators, and Rudder	13
Install the Tail Gear Assembly	15
Assemble and Install the Main Gear	16
Install the Elevator Servos and Pushrods	17
GLOW ENGINE INSTALLATION	18
Mount the Engine	18
Install the Fuel Tank (Glow Engine)	20
Install the Throttle Servo (Glow Engine)	21
GAS ENGINE INSTALLATION	22
Mount the Engine	22
Install the Fuel Tank (Gas Engine)	23
Install the Throttle Servo (Gas Engine)	26
Install the Ignition Equipment (Gas Engine)	27
BRUSHLESS MOTOR INSTALLATION	29
Mount the Motor	29
Install the Battery and ESC Trays	30
INSTALL THE RUDDER SERVOS	33
Install the Rudder Servos in the Forward Position ...	33
Install the Rudder Servos in the Aft Position	36
FINISH THE MODEL	37
Install the Radio System	37
Install the Cowl	39
Install the Canopy Hatch	41
Install the Propeller and Spinner	42
GET THE MODEL READY TO FLY	43
Install and Connect the Motor Battery	43
Check the Control Directions	44
Set the Control Throws	44
Balance the Model (C.G.)	45
Balance the Model Laterally	46
PREFLIGHT	46
Identify Your Model	46
Charge the Batteries	46
Balance Propellers	46
Ground Check	46
Range Check	46

ENGINE SAFETY PRECAUTIONS	47
AMA SAFETY CODE	47
IMAA SAFETY CODE	48
CHECK LIST	49
FLYING	50
Takeoff	50
Flight	50
Landing	50
3D FLYING	51
ENGINE/MOTOR MOUNT TEMPLATES	53

INTRODUCTION

Congratulations on your purchase of the Edge 540 1.60 ARF 3D, the next in the Great Planes Performance Series line of 3D aerobatic airplanes! The Edge 540 is one of the most capable aerobatic planes in the world and has delivered multiple championships in competition. Its proven design will also deliver the 3D performance that pilots have come to expect from the Great Planes Performance Series.

For the latest technical updates or manual corrections to the Edge 540 1.60 ARF visit the Great Planes web site at www.greatplanes.com. Open the "Airplanes" link, then select the Edge 540 1.60 ARF. If there is new technical information or changes to this model a "tech notice" box will appear in the upper left corner of the page.

AMA

We urge you to join the AMA (Academy of Model Aeronautics) and a local R/C club. The AMA is the governing body of model aviation and membership is required to fly at AMA clubs. Though joining the AMA provides many benefits, one of the primary reasons to join is liability protection. Coverage is not limited to flying at contests or on the club field. It even applies to flying at public demonstrations and air shows. Failure to comply with the Safety Code (excerpts printed in the back of the manual) may endanger insurance coverage. Additionally, training programs and instructors are available at AMA club sites to help you get started the right way. There are over 2,500 AMA chartered clubs across the country. Contact the AMA at the address or toll-free phone number below.

Academy of Model Aeronautics

5151 East Memorial Drive

Muncie, IN 47302

Tele: (800) 435-9262

Fax (765) 741-0057

Or via the Internet at:

www.modelaircraft.org



IMPORTANT!!! Two of the most important things you can do to preserve the radio controlled aircraft hobby are to avoid flying near full-scale aircraft and avoid flying near or over groups of people.

IMAA

The Great Planes Edge 540 1.60 ARF is an excellent sport-scale model and is eligible to fly in IMAA events. The IMAA (International Miniature Aircraft Association) is an organization that promotes non-competitive flying of giant-scale models. If you plan to attend an IMAA event, obtain a copy of the IMAA Safety Code by contacting the IMAA at the address or telephone number below, or by logging on to their web site at:

IMAA
205 S. Hilldale Road
Salina, KS 67401
(913) 823-5569
www.fly-ima.org

PROTECT YOUR MODEL, YOURSELF & OTHERS...FOLLOW THESE IMPORTANT SAFETY PRECAUTIONS

1. Your Edge 540 1.60 ARF should not be considered a toy, but rather a sophisticated, working model that functions very much like a full-size airplane. Because of its performance capabilities, the Edge, if not assembled and operated correctly, could possibly cause injury to yourself or spectators and damage to property.
2. You must assemble the model **according to the instructions**. Do not alter or modify the model, as doing so may result in an unsafe or unflyable model. In a few cases the instructions may differ slightly from the photos. In those instances the written instructions should be considered as correct.
3. You must take time to **build straight, true and strong**.
4. You must use an R/C radio system that is in first-class condition, and a correctly sized engine and components throughout the building process.
5. You must correctly install all R/C and other components so that the model operates correctly on the ground and in the air.
6. You must check the operation of the model before **every** flight to insure that all equipment is operating and that the model has remained structurally sound. Be sure to check clevises or other connectors often and replace them if they show any signs of wear or fatigue.
7. If you are not an experienced pilot or have not flown this type of model before, we recommend that you get the assistance of an experienced pilot in your R/C club for your first flights. If you're not a member of a club, your local hobby shop has information about clubs in your area whose membership includes experienced pilots.

8. While this kit has been flight tested to exceed normal use, if the plane will be used for extremely high stress flying, such as racing, or if an engine larger than one in the recommended range is used, the modeler is responsible for taking steps to reinforce the high stress points and/or substituting hardware more suitable for the increased stress.

9. **WARNING:** The cowl and wheel pants included in this kit are made of fiberglass, the fibers of which may cause eye, skin and respiratory tract irritation. Never blow into a part (wheel pant, cowl) to remove fiberglass dust, as the dust will blow back into your eyes. Always wear safety goggles, a particle mask and rubber gloves when grinding, drilling and sanding fiberglass parts. Vacuum the parts and the work area thoroughly after working with fiberglass parts.

We, as the kit manufacturer, provide you with a top quality, thoroughly tested kit and instructions, but ultimately the quality and flyability of your finished model depends on how you build it; therefore, we cannot in any way guarantee the performance of your completed model, and no representations are expressed or implied as to the performance or safety of your completed model.

Remember: Take your time and follow the instructions to end up with a well-built model that is straight and true.

DECISIONS YOU MUST MAKE

This is a partial list of items required to finish the Edge 540 1.60 ARF that may require planning or decision making before starting to build. Order numbers are provided in parentheses.

Building Stand

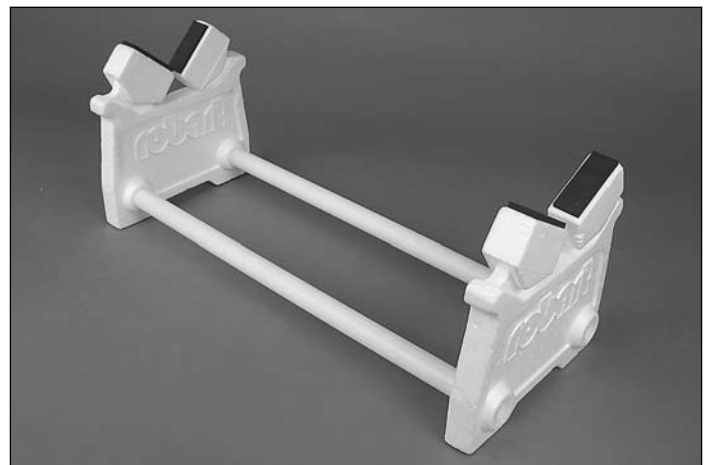

A building stand or cradle comes in very handy during the build. We use the Robart Super Stand II (ROBP1402) for most of our projects in R&D, and it can be seen in pictures throughout this manual.

Radio Equipment

Since the Edge 540 1.60 ARF is a large model capable of extreme aerobatics, standard servos should not be used to operate the control surfaces. Servos with a minimum torque rating of 98 oz-in [7.1kg-cm] are required except for the throttle servo which may be operated by a standard servo. The servos shown in this manual that are used for all of the control surfaces are Futaba® S3305 servos. A minimum of six high torque servos and one standard servo (used for throttle when installing a glow or gas engine) are needed to complete the Edge:

- Futaba S3305 Servo High-Torque Standard w/Metal Gears (FUMT0045)
- Futaba S9001 Servo Aircraft Coreless BB (FUTM0075)

Because of heavy loads on the control surfaces, heavy-duty servo arms should be used on all of the control surface servos. The throttle servo can use the servo arm supplied with the servo. This manual shows the installation of Great Planes 1.5" [38mm] aluminum single-sided servo arms. If the rudder servos will be installed in the aft location, six arms will be needed. If the rudder servos are installed in the forward position, only four arms will be needed. See the building instructions for details on the rudder servo positions.

- Great Planes Large Scale 1.5" Single Side Servo Arm (GPMM1105)

The following servo extensions and Y-harnesses were also used to build the Edge 540 1.60 ARF as shown in the manual:

- Two 36" [914mm] servo extensions for elevator servos (HCAM2726 for Futaba J-connector)
- Two 36" [914mm] servo extensions for rudder servos when installed in the optional aft location (HCAM2726 for Futaba J-connector)
- Two 24" [610mm] servo extensions for aileron servos (HCAM2721 for Futaba J-connector)
- One 6" [152mm] servo extension for receiver battery pack (HCAM2701 for Futaba J-connector)
- One 12" [305mm] servo extension for brushless ESC if applicable (HCAM2711 for Futaba J-connector)

If using a radio system that does not support mixing of the elevator, rudder, and aileron servos, Y-harnesses will be required:

- Two Hobbico® Pro HD Y-Harnesses for rudder and aileron servos (HCAM2751 for Futaba J-connector)
- One Reversing Y-Harness for elevator servos (EMOM0027 for Futaba J-connector)

Note: *The list of servo extensions and Y-harnesses is based on the equipment we used to set up the Edge as detailed in the manual. The length or quantity may vary depending on the actual equipment being used, radio locations, etc.*

A battery pack with a **minimum** of 1500mAh capacity should also be used. When flying large models such as the Edge 540 1.60 ARF, **ALWAYS** check the battery condition before each flight. If you are installing a gas engine with an electronic ignition module, a separate battery pack (the EI pack does not need to be high capacity) will also be required in addition to the battery pack used to power the receiver and servos.

- Hobbico HydriMax™ 4.8V 2000mAh NiMH Flat AA Rx U (HCAM6321)

A heavy-duty receiver switch and charge jack will also be needed:

- Futaba Heavy-duty Switch Harness w/Charge Cord (FUTM4385)
- Ernst Charge Receptacle Futaba J FM (ERNM3001)

If installing a gas engine, an additional switch (standard size) and charge jack will also be needed:

- Futaba SWH13 Switch Harness & Charge Cord Mini J (FUTM4370)

Engine Recommendations

The recommended engine size range for the Edge 540 1.60 ARF is 1.6 to 1.8 cu in [26–30cc] two-stroke glow engine, 1.8 to 2.1 cu in [30–34cc] four-stroke glow engine, or 1.9 to 2.6 cu in [32–43cc] gasoline engine. We recommend either the O.S.® 1.60 FX glow engine (OSMG0661) or the Fuji-Imvac™ BT-43 EI-2 gasoline engine (FJIG0144). The Edge is also designed to accept a Great Planes 63-62-250kV RimFire™ brushless out-runner motor. All of these power systems will allow the Edge to perform the 3D maneuvers it was designed for and installations are covered in this manual.

GLOW ENGINE REQUIREMENTS

The only required accessory needed to install a glow engine is a Pitts style muffler. If using the O.S. 1.60 FX glow engine, the order number for a Pitts style muffler is Bisson O.S. 1.60 FX Pitts Muffler (BISG4116).

BRUSHLESS MOTOR REQUIREMENTS

If installing the Great Planes 63-62-250kV RimFire out-runner brushless motor (GPMG4795), you will also need to purchase:

- Great Planes Brushless Motor Mount Extra Large (GPMG1265)
- Great Planes SS100 100A Brushless ESC (GPMM1870)
- 9-12 cells (3 or 4 11.1V packs) 3200mAh LiPo Batteries: Great Planes LiPo 11.1V 3200mAh 20C Discharge w/ Balance (GPMP0623)
- Great Planes Series Deans® Ultra Plug® 2 to 1 Adapter (GPMM3143)
- Great Planes Velcro Hook & Loop 1x6" (2) (GPMQ4480)
- LiPo compatible battery charger such as the Great Planes PolyCharge4™ DC Only 4 Output LiPo Charger (GPMM3015)
- Great Planes ElectriFly™ Equinox™ LiPo Cell Balancer (GPMM3160)

The included spinner adapter nut is designed specifically to fit into the tapered jam nut used on the O.S. 1.60 FX glow engine. Because of this, an adapter nut must be purchased to work with the RimFire prop adapter. You can use Tru Turn Adapter Kit O.S. 1.08 (TRUQ3065) or Dave Brown X-Long Adapter Nut 3/8-24 (DAVQ6324). Both of these adapter nuts require a 10-32 spinner bolt that will need to be purchased separately. The length of the bolt will depend on the adapter nut being used. We suggest purchasing a 10-32 x 2-3/4" [70mm] spinner bolt and cutting it to the necessary length. Another option is to purchase the nut and prop washer set for the O.S. 1.60 FX engine, O.S. Locknut Set 1.60 FX (OSMG6688). Using the O.S. prop nut will allow you to also use the adapter nut included with the kit as well as the included 5mm prop bolt.

Note: The total recommended voltage for the LiPo battery pack configuration is 33.3V to 44.4V. This can be done in combinations of battery packs ranging in voltage. Be sure that the capacity (mAh) of all packs used are the same value (example: do not mix 3200mAh packs with 5000mAh packs). The battery pack combination should be connected together using the recommended series adapter. The actual quantity of adapters needed depends on the number of packs being used. Each adapter will connect two packs together in series. If three 11.1V packs are joined to make 33.3V, two series adapters will be needed (one series adapter will join two 11.1V packs together to make 22.2V, the second adapter will combine that 22.2V with the remaining 11.1V pack for a total of 33.3V). If four 11.1V packs are combined for a total of 44.4V, then three series adapters will be needed. Other voltage combinations may require more or less adapters.

The recommended hook and loop material is used to join the individual battery packs together, securing them onto the battery tray, and securing the ESC to the ESC tray. One package of Great Planes hook and loop contains 12" [305mm] of material. We suggest purchasing at least two packages.

The recommended PolyCharge4 will charge up to four LiPo packs simultaneously. To do so, an Equinox Cell Balancer is required for each individual LiPo pack. The PolyCharge4 is a DC only charger, so a suitable DC power source will also be required.

GAS ENGINE REQUIREMENTS

The fuel tank included with this kit is suitable for use with glow fuel. However, if using a gas engine, the fuel tank must be converted to work with gasoline. This can be done by purchasing a Sullivan #484 Gasoline/Diesel fuel tank conversion kit (SULQ2684), two packages of Du-Bro #813 1/8" [3.2mm] I.D. fuel line barbs (DUBQ0670) and at least 3' [914mm] of gasoline compatible fuel tubing (such as Tygon). Without the fuel line barbs, some types of gas-compatible fuel line may slip off the metal fuel tubes. If the Sullivan conversion kit is not available, the Du-Bro #400 gas conversion stopper (DUBQ0675) and one package of K&S 1/8" [3.2mm] soft brass tubing (K+SR5127) could also be used to make the conversion.

Also, the hardware needed to mount a gas engine to the firewall is not included with the kit. The hardware that is detailed in the building instructions of this manual for mounting the Fuji-Imvac BT-43 EI-2 engine includes four 10-32 x 1-1/4" [32mm] socket head cap screws, four #10 flat washers, four #10 lock washers (split washers), and four 10-32 blind nuts. This hardware can be purchased at a hardware store, home center, or your hobby supplier.

Propeller

Choose the propeller that is appropriate for the power system you are using. If installing the Great Planes 63-62-250kV RimFire out-runner motor, the propeller choice will depend on the battery voltage being used. A 9-cell (33.3V) pack will require a 20 x 10 prop (APCQ2200). A 12-cell (44.4V) pack will require an 18 x 8 prop (APCQ3010). If installing an O.S. 1.60 FX glow engine, we recommend using a 18 x 6W prop (APCQ1806). If installing the Fuji-Imvac BT-43 EI-2 engine, we recommend using a 20 x 8 prop (APCQ2080).

ADDITIONAL ITEMS REQUIRED

Adhesives and Building Supplies

This is the list of Adhesives and Building Supplies that are required to finish the Edge 540 1.60 ARF.

- Pro 30-minute epoxy (GPMR6047)
- 1/2 oz. [15g] Thin Pro™ CA (GPMR6001)
- 1/2 oz. [15g] Medium Pro CA+ (GPMR6007)
- Hobbico 60 watt soldering iron (HCAR0776) *or* Hobby Heat™ Micro Torch II (HCAR0755)
- Silver solder w/flux (STAR2000)
- Petroleum jelly (Vaseline)
- 3' [900mm] standard silicone fuel tubing (GPMQ4131) (glow engine only)
- R/C foam rubber (1/4" [6mm] - HCAQ1000)
- Drill bits: 1/16" [1.6mm], 3/32" [2.4mm], 7/64" [2.8mm], 1/8" [3.2mm], 9/64" [3.6mm], 5/32" [4mm], 3/16" [4.8mm], 7/32" [5.6mm], 3/16" [4.8mm], 1/4" [6.4mm]
- Denatured alcohol (for epoxy clean up)
- 8-32 tap and drill set (GPMR8103), *glow engine only*
- Tap handle (GPMR8120), *glow engine only*
- #1 Hobby knife (HCAR0105)
- #11 blades (5-pack, HCAR0211)
- Masking tape (TOPR8018)
- T-pins (HCAR5150)
- Great Planes Pro Threadlocker (GPMR6060)
- Dead Center™ Engine Mount Hole Locator (GPMR8130), *glow engine only*
- Panel Line Pen (TOPQ2510)
- 1" [25mm] double-sided foam tape (GPMQ4442)
- 220-grit Sandpaper (GPMR6185)
- 21st Century® sealing iron (COVR2700)
- 21st Century iron cover (COVR2702)
- 21st Century trim seal iron (COVR2750)

Optional Supplies and Tools

Here is a list of optional supplies and tools that will help you build the Edge 540 1.60 ARF.

- Great Planes 1/4 Sport Pilot Yellow (GPMQ9012)
- Fuel filler valve for glow fuel (GPMQ4160)
- Fuel filler valve for gasoline (GPMQ4161)
- 1/2 oz. [15g] Thick Pro CA- (GPMR6013)
- Stick-on segmented lead weights (GPMQ4485)
- Epoxy brushes (6, GPMR8060)
- Mixing sticks (50, GPMR8055)
- Mixing cups (GPMR8056)
- Builder's Triangle Set (HCAR0480)
- 36" metal ruler (HCAR0475)
- Pliers with wire cutter (HCAR0630)
- T.A. Emerald Performance Duster can of compressed air (TAEC1060)
- Rotary tool such as Dremel
- Rotary tool reinforced cut-off wheel (GPMR8200)
- Servo horn drill (HCAR0698)
- CG Machine™ (GPMR2400)
- #64 Rubber bands (1/4 lb [113g] box, HCAQ2020)

IMPORTANT BUILDING NOTES

- There are two types of screws used in this kit:

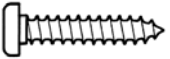
Self-tapping screws are designated by a number and a length. For example,  #6 x 3/4" [19mm].

Machine screws are designated by a number, threads per inch, and a length.  For example, 4-40 x 3/4" [19mm].

Socket Head Cap Screws (SHCS) are designated by a number, threads per inch, and a length. For example,  4-40 x 3/4" [19mm]

- When you see the term **test fit** in the instructions, it means that you should first position the part on the assembly **without using any glue**, then slightly modify or *custom fit* the part as necessary for the best fit.
- Whenever the term **glue** is written you should rely upon your experience to decide what type of glue to use. When a specific type of adhesive works best for that step, the instructions will make a recommendation.
- Whenever just **epoxy** is specified you may use **either** 30-minute (or 45-minute) epoxy **or** 6-minute epoxy. When 30-minute epoxy is specified it is **highly** recommended that you use only 30-minute (or 45-minute) epoxy, because you will need the working time and/or the additional strength.

- **Photos** and **sketches** are placed **before** the step they refer to. Frequently you can study photos in following steps to get another view of the same parts.
- The stabilizer and wing incidences and engine thrust angles have been factory-built into this model. However, some technically-minded modelers may wish to check these measurements anyway. To view this information visit the web site at **www.greatplanes.com** and click on "Technical Data." Due to manufacturing tolerances which will have little or no effect on the way your model will fly, please expect slight deviations between your model and the published values.
- The Edge 540 1.60 ARF is factory-covered with Top Flite® MonoKote® film. Should repairs ever be required, MonoKote can be patched with additional MonoKote purchased separately. MonoKote is packaged in six-foot rolls, but some hobby shops also sell it by the foot. If only a small piece of MonoKote is needed for a minor patch, perhaps a fellow modeler would give you some. MonoKote is applied with a model airplane covering iron, but in an emergency a regular iron could be used. A roll of MonoKote includes full instructions for application. Following are the colors used on this model and order numbers for six foot rolls.

Yellow (TOPQ0203)
White (TOPQ0204)
Missile Red (TOPQ0201)
Metallic Blue (TOPQ0402)

ORDERING REPLACEMENT PARTS

Replacement parts for the Edge 540 1.6 ARF are available using the order numbers in the Replacement Parts List that follows. The fastest, most economical service can be provided by your hobby dealer or mail-order company.

To locate a hobby dealer, visit the Great Planes web site at **www.greatplanes.com**. Choose "Where to Buy" at the bottom of the menu on the left side of the page. Follow the instructions provided on the page to locate a U.S., Canadian or International dealer.

Parts may also be ordered directly from Hobby Services by calling (217) 398-0007, or via facsimile at (217) 398-7721, but full retail prices and shipping and handling charges will apply. Illinois and Nevada residents will also be charged sales tax. If ordering via fax, include a Visa® or MasterCard® number and expiration date for payment.

Mail parts orders and payments by personal check to:

Hobby Services
 3002 N. Apollo Drive, Suite 1
 Champaign, IL 61822

Be certain to specify the order number exactly as listed in the **Replacement Parts List**. Payment by credit card or personal check only; no C.O.D.

If additional assistance is required for any reason, contact Product Support by telephone at (217) 398-8970, or by e-mail at **productsupport@greatplanes.com**.

REPLACEMENT PARTS LIST

Order Number	Description	How to Purchase
	Missing pieces	Contact Product Support
	Instruction manual	Contact Product Support
	Full-size plans.....	Not available

Contact your hobby supplier for the following parts:

- GPMA3080 Wing Set
- GPMA3081 Fuselage
- GPMA3082 Tail Set
- GPMA3083 Cowl
- GPMA3084 Canopy
- GPMA3085 Landing Gear
- GPMA3086 Wheel Pants
- GPMA3087 Decal
- GPMA3088 Canopy/Hatch
- GPMA3089 Spinner

KIT INSPECTION

Before starting to build inspect the parts to make sure they are of acceptable quality. If any parts are missing or are not of acceptable quality, or if you need assistance with assembly, contact **Product Support**. When reporting defective or missing parts, use the part names exactly as they are written in the Kit Contents list.

Great Planes Product Support
3002 N. Apollo Drive, Suite 1
Champaign, IL 61822
Telephone: (217) 398-8970, ext. 5
Fax: (217) 398-7721
E-mail: airsupport@greatplanes.com

KIT CONTENTS

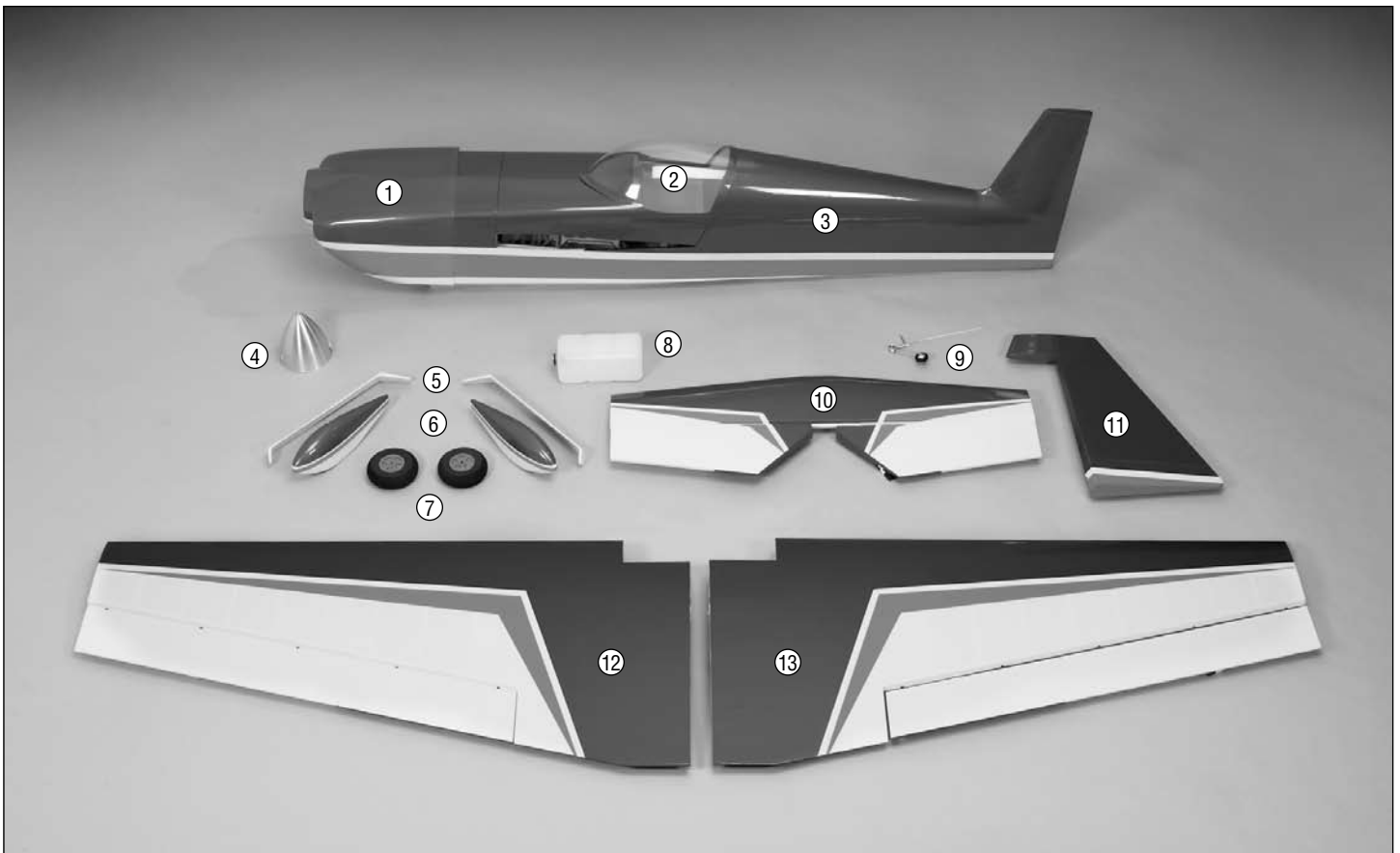

- | | |
|-----------------|---------------------------------------|
| 1. Cowl | 8. Fuel Tank |
| 2. Canopy | 9. Tailwheel Assembly |
| 3. Fuselage | 10. Horizontal Stabilizer w/Elevators |
| 4. Spinner | 11. Rudder |
| 5. Landing Gear | 12. Left Wing w/Aileron |
| 6. Wheel Pants | 13. Right Wing w/Aileron |
| 7. Main Wheels | |

PREPARATIONS

1. If you have not done so already, remove the major parts of the kit from the box and inspect for damage. If any parts are damaged or missing, contact Product Support at the address or telephone number listed in the "Kit Inspection" section on the previous page.

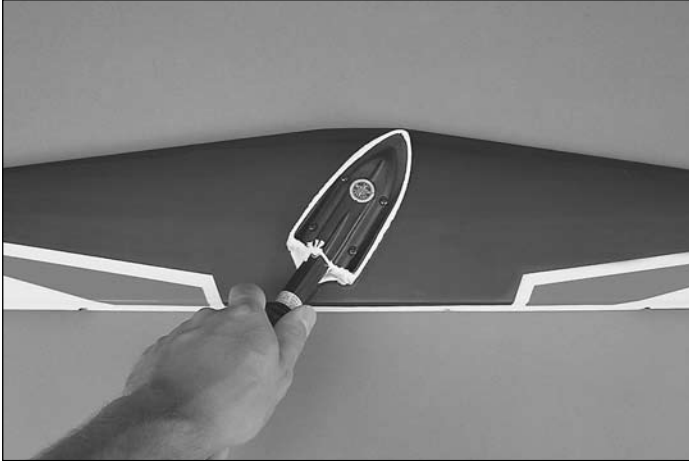

2. Carefully remove the tape and separate all the control surfaces. Use a covering iron with a covering sock on medium/high heat to tighten the covering if necessary. Apply pressure over sheeted areas to **thoroughly** bond the covering to the wood.

ASSEMBLE THE WING

Install the Ailerons

Do the left wing first so your work matches the photos the first time through. You can do one wing at a time, or work on them together.

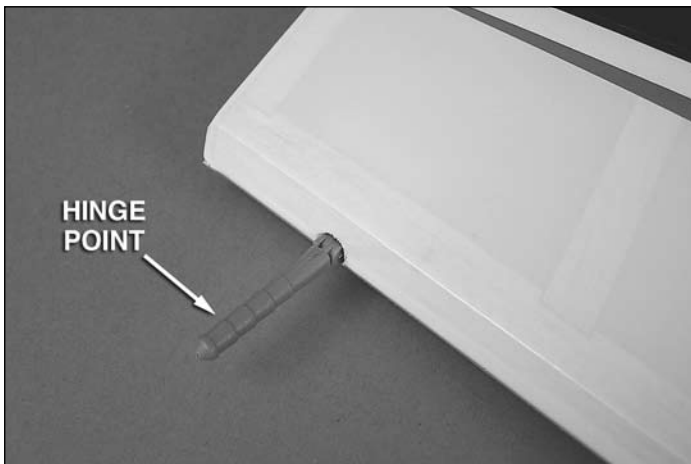

1. Test fit the included hinge points into the pre-drilled holes in the **wing panel** and **aileron**. The hinge points should seat into the hinge holes all the way to the metal pin in order to minimize the gap between the aileron and wing. If necessary, use a hobby knife to enlarge the surface of the hinge holes until the proper fit is achieved. Test fit the aileron

to the wing. The hinge gap between the aileron and wing should only be wide enough to allow a small line of light through. Excessive gap will decrease the effectiveness of the ailerons.

2. Apply a small amount of petroleum jelly or something similar to the center of each hinge to prevent epoxy from sticking to the joints and not allowing the hinge to operate smoothly.

READ ALL OF STEP 3 BEFORE PROCEEDING.

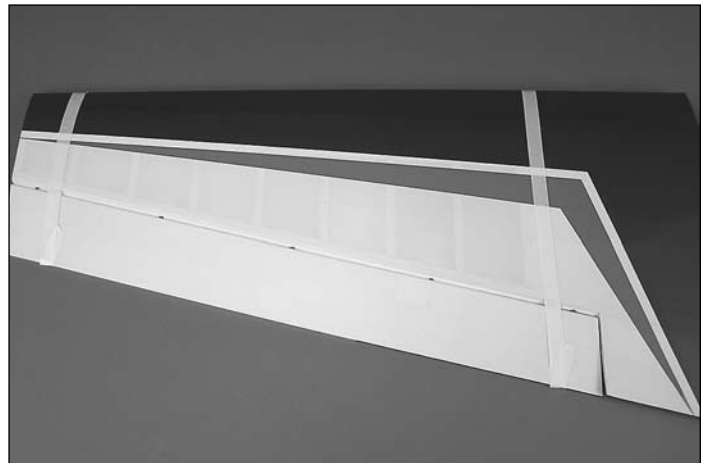
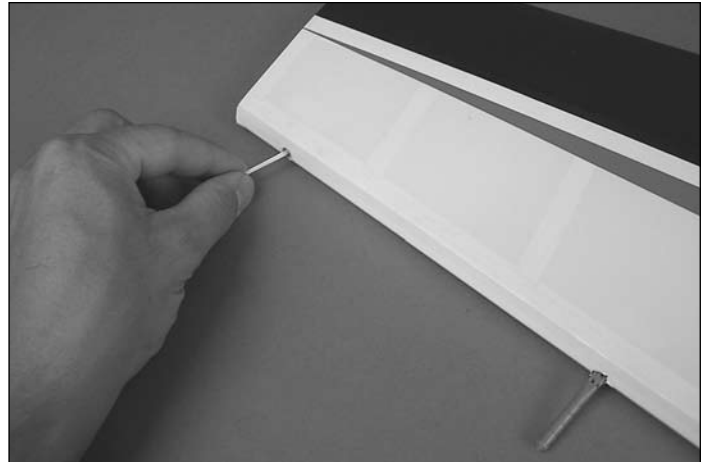

3. Mix up a batch of 30-minute epoxy. Using a toothpick or wood scrap, apply epoxy to the inside of each hinge point hole. The holes are drilled through to the open cavity in the wing and aileron, so be careful that you do not apply too much to the walls of the holes as it will simply drip into the wing. Apply a light coat of epoxy to one end of all the hinges for one wing panel. Insert the hinge points into the holes in the wing panel, wiping away excess epoxy with denatured alcohol as necessary. Be sure the hinges are inserted in the correct orientation so that the direction of the hinge pin is inline with trailing edge of the wing. Apply epoxy to the other ends of the hinges and slide the aileron into position over the hinges. Use masking tape to hold the aileron in place while the epoxy cures.

4. Repeat these steps for the right wing panel.

Install Aileron Servos and Pushrods

❑❑ 1. Installing the servos in the wing will require the use of one 24" [610mm] servo extension for each aileron servo. One Y-harness connector is required and is used to allow the aileron servos to plug into one slot in your receiver. You may have a computer radio that allows you to plug the servos into separate slots and then mix them together through the radio transmitter. If you choose to mix them together with the radio rather than a Y-harness, refer to the manual with your particular model radio system.

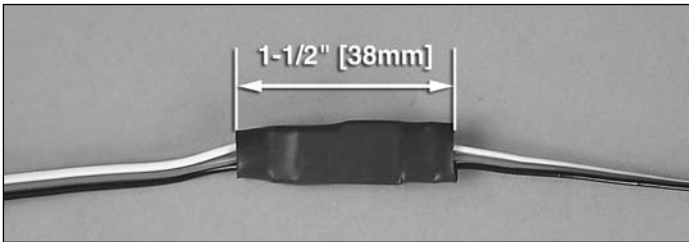

❑❑ 2. Attach the 24" [610mm] servo extension to the aileron servo and secure it with a piece of the included large heat shrink tubing. Only 1-1/2" [38mm] of heat shrink tubing is required for each connector.



❑❑ 3. Cut the covering 1/8" [3mm] inside the opening in the underside of the wing for the aileron servo. Use a trim iron to seal the covering to the inner edges of the opening.

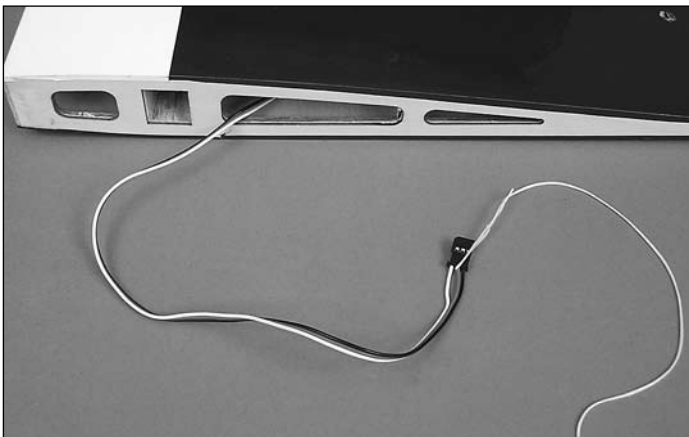

❑❑ 4. Tie the string from inside the opening for the aileron servo to the end of the servo extension. Remove the tape holding the other end of the string to the wing root rib and pull the servo wire and extension through the wing.



❑❑ 5. Temporarily position the aileron servo into the servo bay. Drill a 1/16" [1.6mm] hole through the four mounting holes of the servo, drilling through the plywood mounting plate in the wing. Install and remove a servo mounting screw into each of the four holes. Apply a drop of thin CA into the holes to harden the wood. After the glue has cured, install the servo into the opening using the hardware that came with your servo. Center the servo with your radio system and install a servo arm as shown.

The next three images are used for steps 6 and 7.

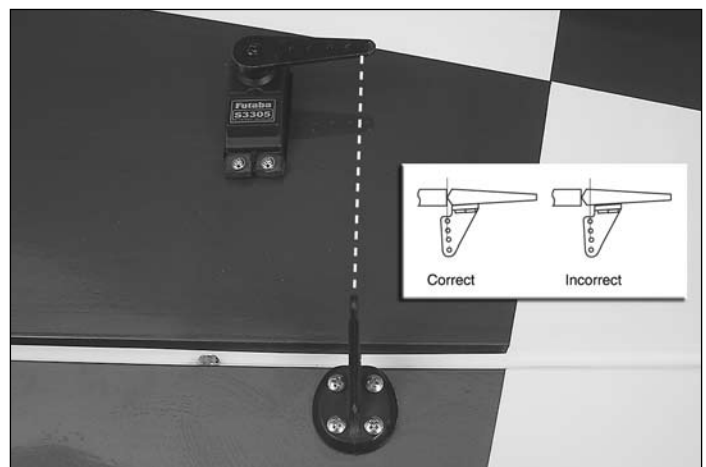

❑❑ 6. The aileron has a plywood plate for mounting the control horn. You can see the outline of it underneath the covering by looking at the aileron at a shallow angle. If you cannot see it, the plate is approximately 1-5/8" [41mm] wide and will be

inline with the servo arm. Use a T-pin to lightly puncture the covering to be sure you are over the plywood plate.

7. Place a heavy-duty **nylon control horn** on the aileron, positioning it as shown in the sketch inline with the second outer hole of the servo arm. Mark the location for the screw holes. Drill through the marks you made with a 3/32" [2.4mm] drill bit (Be sure you are drilling into the plywood plate mounted in the bottom of the aileron. Drill through the plate only. **Do not drill all the way through the aileron!**). Using a #4 x 1/2" [13mm] sheet metal screw (there are different length #4 sheet metal screws included with the model, so be sure that you are using the correct length screw for this step), install and then remove a screw into each of the holes. Harden the holes with thin CA. Install the control horn with four #4 x 1/2" [13mm] sheet metal screws.

8. Locate a .095" x 6" [2.4mm x 152mm] pushrod wire threaded on one end. Screw a 4-40 nut, a silicone clevis retainer and a threaded metal clevis onto the threaded end of the wire 20 turns. Tighten the nut against the clevis and then install the clevis on the outer hole of the aileron control horn.

9. Be sure the aileron servo is centered and the servo arm is parallel to the hinge line. Install a metal solder clevis onto the second outer hole in the servo arm. Center the servo arm parallel with the aileron hinge line and center the aileron. Using the solder clevis as a guide, mark where to cut the pushrod wire. Remove the pushrod and clevis from the control horn and the solder clevis from the servo arm. Install another silicone clevis retainer onto the wire and solder the clevis to the pushrod using the "Expert Tip" that follows.

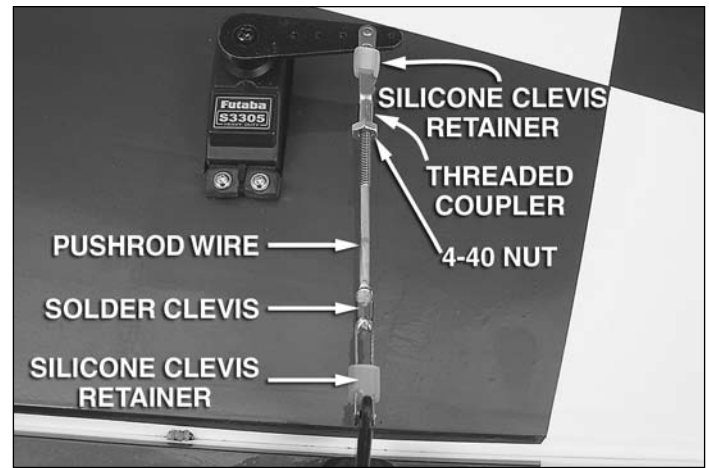

10. Install the pushrod and clevises to the second outer hole in the servo arm and the outer hole in the control horn. Adjust the linkage until the aileron and the servo arm are both centered. Then tighten the nut against the clevis with threadlocking compound. Slide the two silicone clevis retainers to the end of each clevis.

11. Repeat these steps for the right wing panel.

Join the Wing Panels

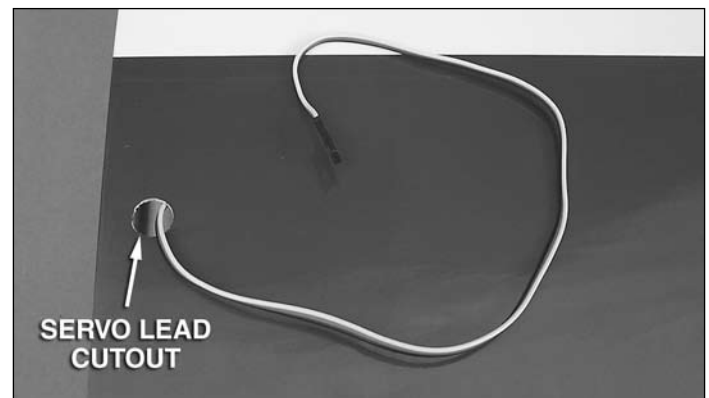

1. Trim the covering from the servo lead cutouts in the bottom of the wing panels near the root ribs. Feed the aileron servo leads through the cutouts. Taping the leads to the top of the wing will keep them out of the way when joining the wing panels.

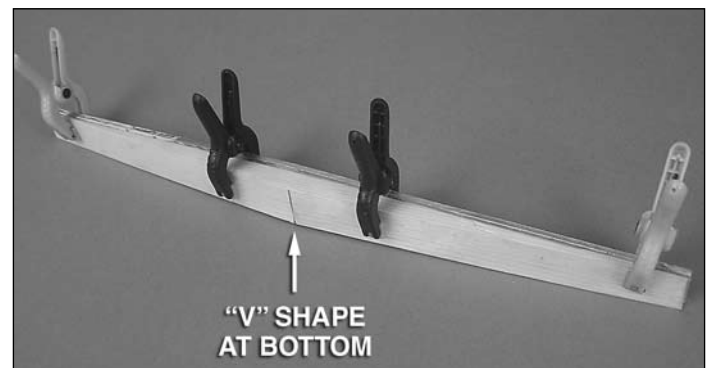

2. Locate the two aluminum **wing joiner** pieces and the wood wing joiner piece. Use 220 grit sandpaper to thoroughly

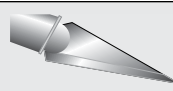

EXPERT TIP

HOW TO SOLDER THE CLEVIS TO THE PUSHROD

1. Where the pushrod will make contact with the solder clevis, roughen the wire with 220-grit sandpaper.
2. Use denatured alcohol to remove any oil residue from the pushrod wire. **Note:** Soldering should be done with silver solder, not an electrical solder.
3. Apply a couple of drops of flux to the wire. Slide the solder clevis onto the wire. Using a small torch or soldering iron heat the wire, allowing the heated wire to heat the solder clevis. Apply a small amount of solder to the joint. When the wire and the clevis are hot enough the solder will flow into the joint. Avoid using too much solder causing solder to flow out of the joint and clump. Use just enough solder to make a good joint. Allow the wire and clevis to cool.
4. Put a couple of drops of oil onto a rag and wipe the joint. This will prevent rust from forming on the joint.

roughen both sides of each aluminum wing joiner piece and remove the sanding dust from the pieces. Glue the three pieces together using 30-minute epoxy with the two aluminum pieces against the flat side of the wood piece. Note that the joiner has a slight "V" shape that will give the wing a small amount of dihedral when assembled. The point of the "V" shape is the **bottom** of the joiner. Wipe away any excess epoxy with a cloth dampened with denatured alcohol and use clamps to hold the pieces together while the epoxy cures. Be sure that the joiner pieces are glued so the edges are flush with each other. Mark a centerline on the assembled wing joiner.

Read all of step 3 and dry fit the parts together to ensure a proper fit before gluing. Sand the wing joiner or root ribs if necessary to achieve the correct fit. The root ribs should join together tightly with no gaps.

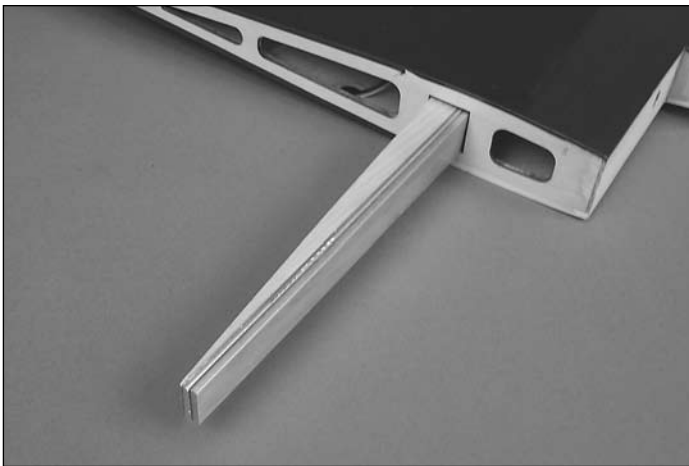

❑ 3. Use a mixing stick or something similar to coat the inside of the wing joiner pockets of both wing panels with 30-minute epoxy. Thoroughly coat one half of the wing joiner with 30-minute epoxy and insert it into the joiner pocket of one wing panel with the bottom of the "V" shape pointing to the underside of the wing and the aluminum pieces toward the LE of the wing. Coat the root ribs of both wing panels and the protruding end of the wing joiner with epoxy. Slide the wing panels together and use tape to hold them tight while the epoxy cures. A small clamp can be used to align the trailing edge while the epoxy cures. Wipe away any excess epoxy with denatured alcohol.

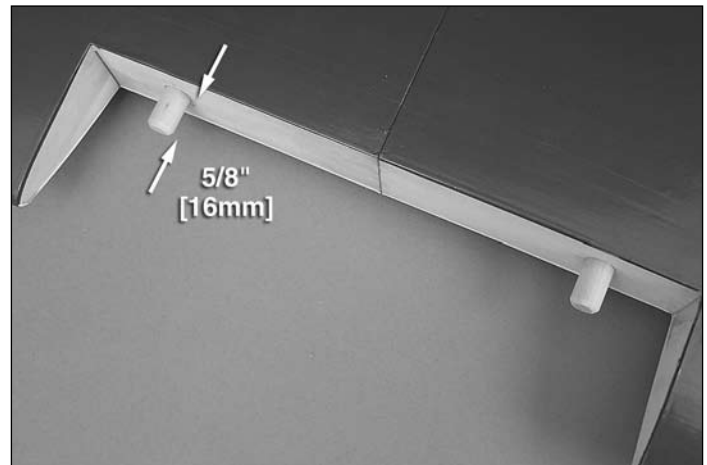
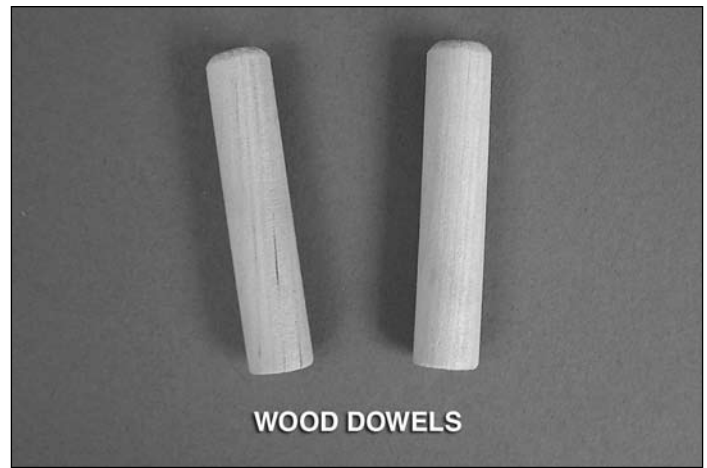

❑ 4. Bevel the ends of the 3/8" x 2" [10x51 mm] wing dowels. Use epoxy to glue the wing dowels in place. Position the dowels so that 5/8" [16mm] protrudes beyond the front of wing.

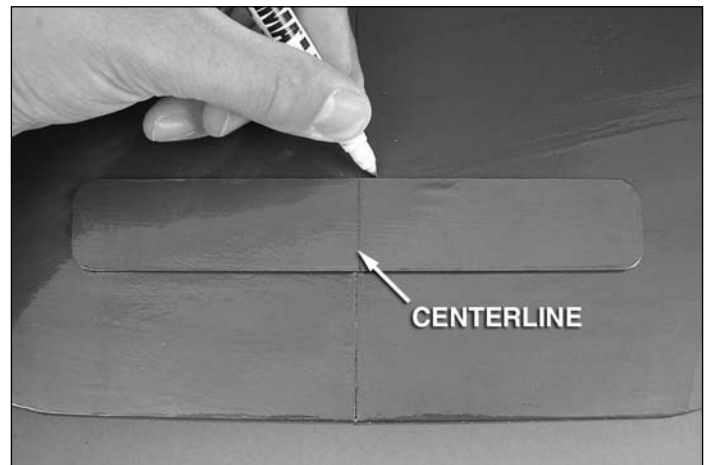

❑ 5. Draw a center line onto the plywood wing bolt plate as shown. Position the wing bolt plate over the wing bolt holes on the underside of the wing and use a felt-tip pen to trace around it.

ASSEMBLE THE TAIL SECTION AND LANDING GEAR

Install Stabilizer, Elevators, and Rudder

- 1. Just as you did with the ailerons, prepare the hinge point holes in the **stabilizer** and **elevators** by test fitting the hinges and enlarging the holes as necessary. Do not glue the hinges until instructed to do so.



- 2. Locate the stabilizer slots near the aft end of the **fuselage** and trim away the covering.

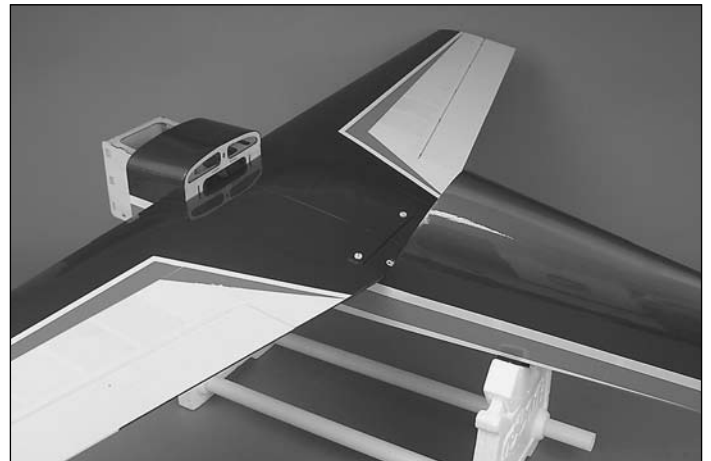

- 3. Temporarily install the wing onto the fuselage using two 1/4-20 nylon wing bolts. The wing dowels will fit into receiving holes in the former behind the leading edge of the wing.

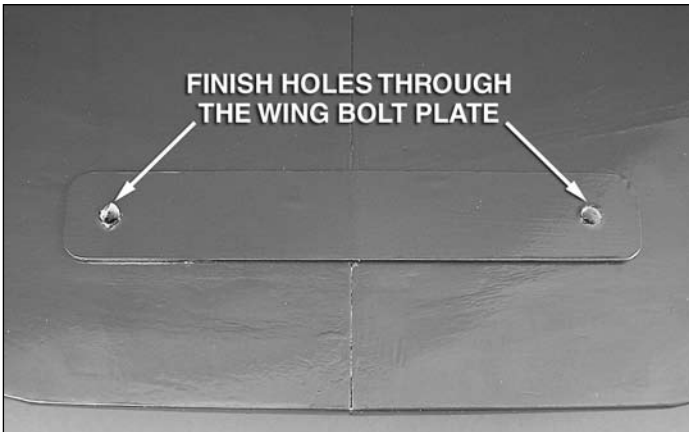
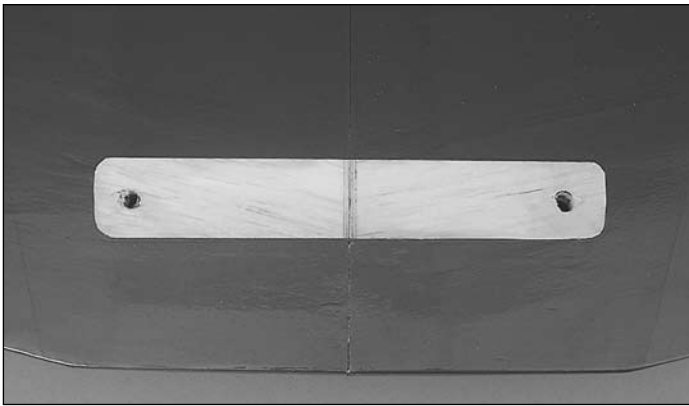

- 6. Use a sharp #11 hobby knife or use the following Expert Tip to cut the covering 1/16" [1.6mm] inside of the lines you marked. Use care to cut only in the covering and not into the wood. Use alcohol to wipe away the lines. Glue the wing bolt plate in position. Continue the wing bolt holes through the plate using a 1/4" [6mm] drill bit. Clamp a piece of scrap wood against the wing bolt plate to reduce tear out when drilling the holes.

EXPERT TIP

HOW TO CUT COVERING FROM BALSA

Use a soldering iron to cut the covering from the area beneath the wing bolt plate. The tip of the soldering iron doesn't have to be sharp, but a fine tip does work best. Allow the iron to heat fully.

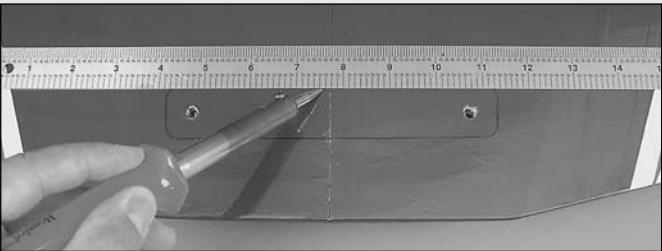

Use a straightedge to guide the soldering iron at a rate that will just melt the covering and not burn into the wood. The hotter the soldering iron, the faster it must travel to melt a fine cut. Peel off the covering.

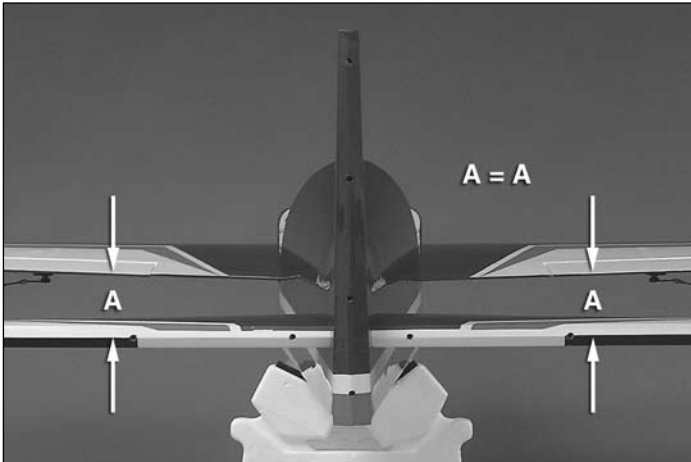

❑ 4. Test fit the stabilizer in the fuselage. Center the stab left and right in the fuselage. Stand back 15-20ft [5-6m] and check to be sure the stab is parallel to the wing. If necessary, adjust the stab saddle as needed until the stab and wing are parallel.

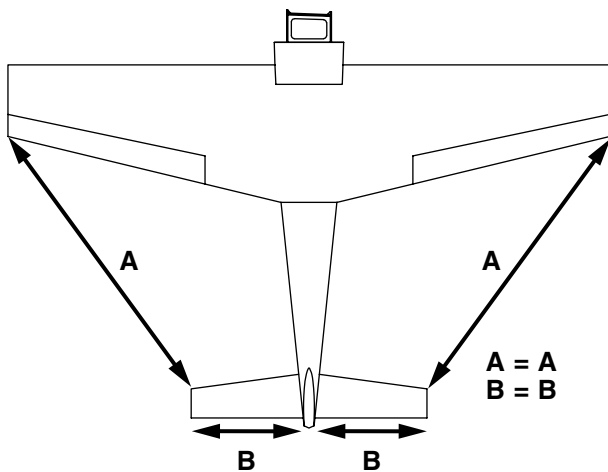

❑ 5. Measure the distance from the tip of each wing to the tip of the stab. Adjust the stab until the distance from the tip of the stab to the tip of the wing is equal on both sides.



❑ 6. Use a felt tip marker to mark the outline of the fuselage onto the top and bottom of the stab.

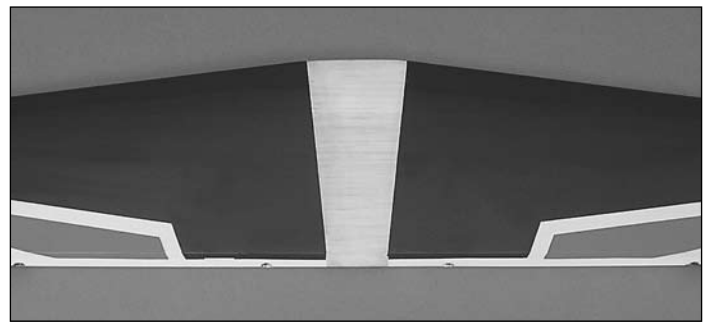

❑ 7. Remove the stab from the fuse and cut the covering just inside the lines you drew. If using a hobby knife to remove the covering, use care to **cut only in the covering** and **not into the wood**.

❑ 8. Use 30-minute epoxy to glue the stab into the fuselage. For the most strength, apply epoxy to both sides of the stab and inside the fuse where the stab fits. Slide the stab into position. Confirm that the stab is centered and parallel with the wing as was done in steps 4 and 5. Wipe away any excess epoxy with a paper towel and denatured alcohol. Do not disturb the model until the epoxy has fully hardened. With the stab secure, you can now remove the wing from the plane.

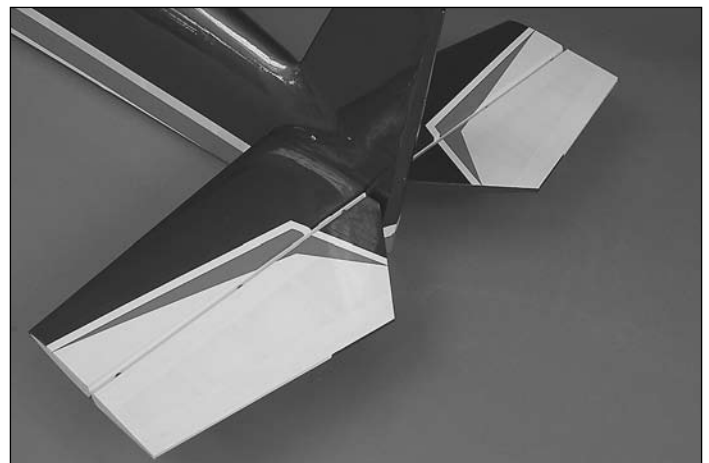

❑ 9. As you did with the ailerons, use a toothpick or wood scrap to apply 30-minute epoxy to the inside of each elevator and stab hinge point hole. Apply a light coat of epoxy to one

end of all the hinges for the elevators along with a small amount of petroleum jelly at the center of each hinge. Insert the hinge points into the holes, wiping away excess epoxy with denatured alcohol as necessary. Be sure the hinges are inserted in the correct orientation. Apply epoxy to the other ends of the hinges and slide the elevators into place. Use masking tape to hold the elevators in position while the epoxy cures.

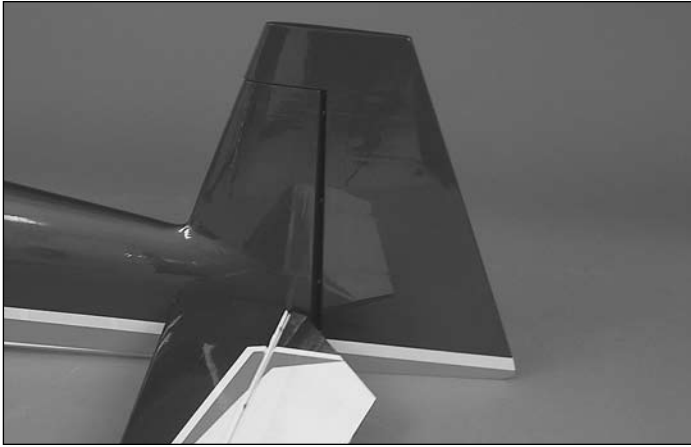

❑ 10. Attach the rudder in the same manner.

Install the Tail Gear Assembly



❑ 1. Trim the covering from the fuselage for the **tail gear bushing**.



❑ 2. Apply CA or epoxy to the outside of the bushing and insert the bushing into the hole by gently tapping it into place until fully seated. Be sure not to get glue into the hole in the bushing.

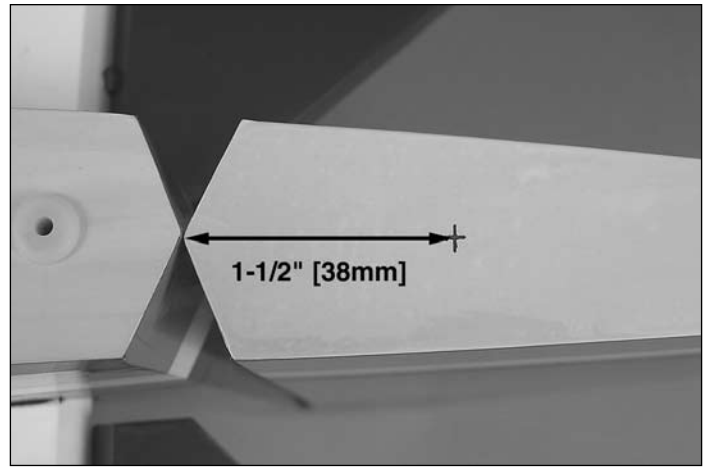

❑ 3. Measure 1-1/2" [38mm] back from the LE level of the rudder and make a mark on the underside center of the rudder.

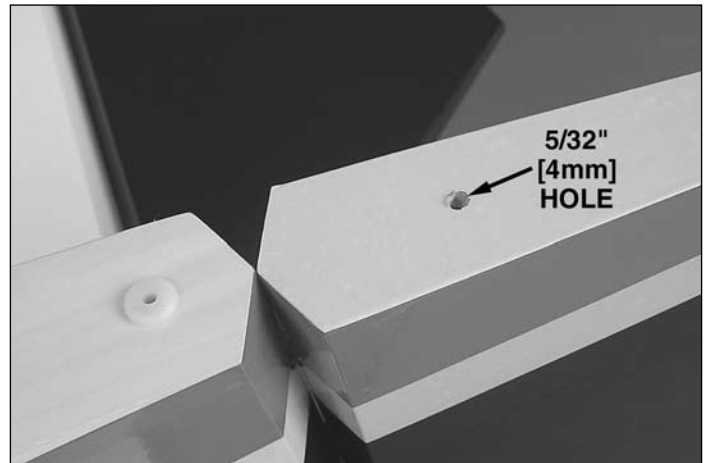

❑ 4. Use a 5/32" [4mm] drill bit to make a 1/2" [13mm] deep hole at the mark. To improve accuracy, drill a smaller pilot hole at your mark first.

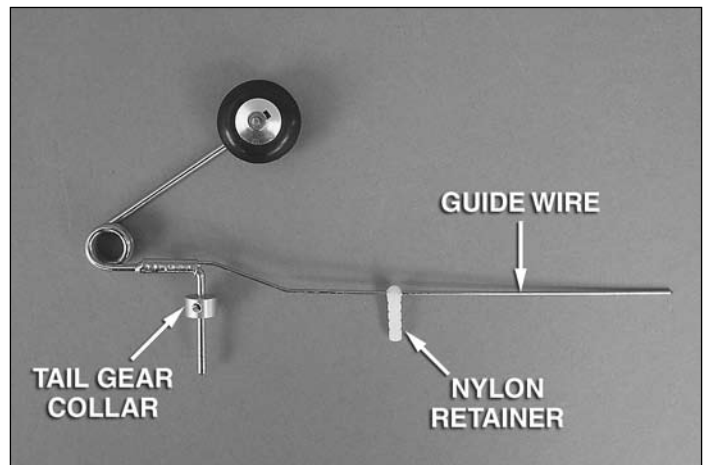

❑ 5. Slide the **tail gear collar** and **nylon retainer** onto the **tail gear assembly** as shown. If necessary, use a 1/16" [1.6mm] drill bit to enlarge the hole in the retainer for the tail gear guide wire.

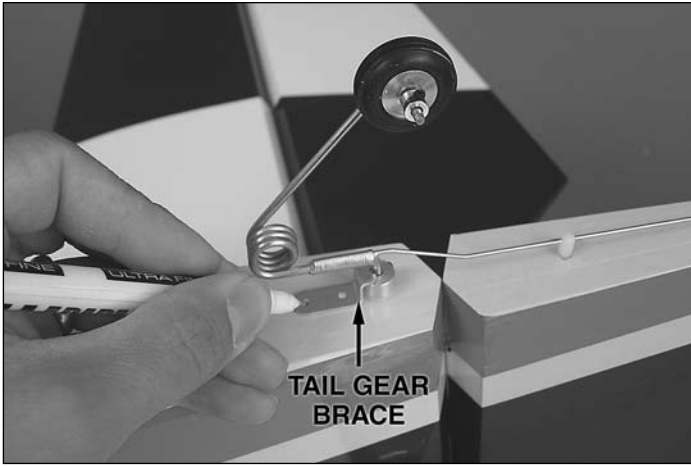

❑ 6. Temporarily insert the tail gear assembly into the tail gear bushing and the nylon retainer into the hole you drilled in the rudder. Center the **tail gear bracket** onto the fuselage over the tail gear collar and mark the location of the mounting holes.

❑ 7. Drill 1/16" [1.6mm] holes at the marks you made. Thread a 2x8mm self-tapping screw into each hole and back it out. Apply a couple drops of thin CA glue to each hole and allow it to harden.

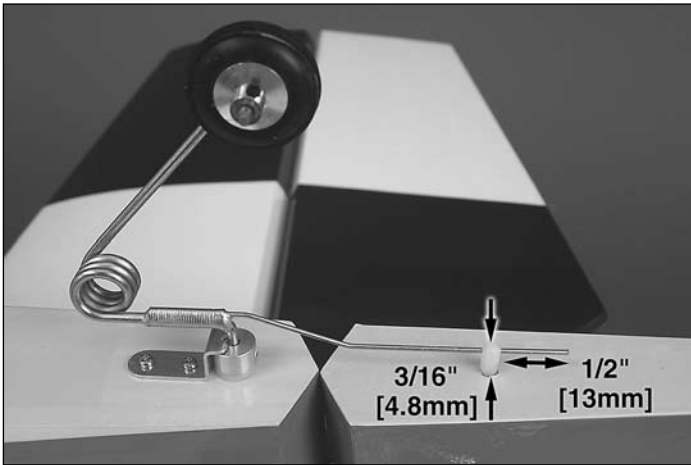

❑ 8. Apply CA or epoxy to the nylon retainer and reinstall the tail gear assembly into the bushing and rudder. Do not glue the nylon retainer to the guide wire. The wire must slide freely through the hole in the retainer. Gently tap the retainer in place until approximately 3/16" [4.8mm] protrudes below the bottom of the rudder. Attach the tail gear bracket using two 2 x 8mm self-tapping screws. Thread the 3mm set screw into the tail gear collar with a drop of threadlocking compound. Cut off the excess guide wire 1/2" [13mm] behind the nylon retainer.

❑ 9. Confirm that the tail wheel rotates freely. Oil the axle and adjust the position of the 3mm wheel collar if necessary.

Assemble and Install the Main Gear

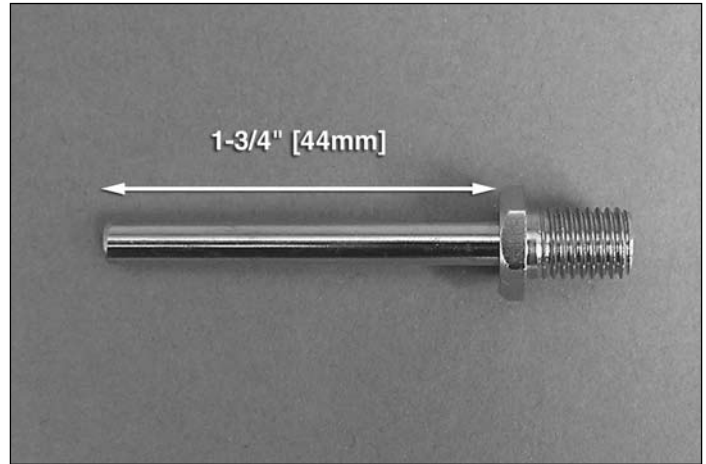

❑ 1. Use a rotary tool with a cutoff wheel or a hacksaw to cut the two 3/16" x 2" [4.8mm x 51mm] bolt-on axles to 1-3/4" [44mm] long.

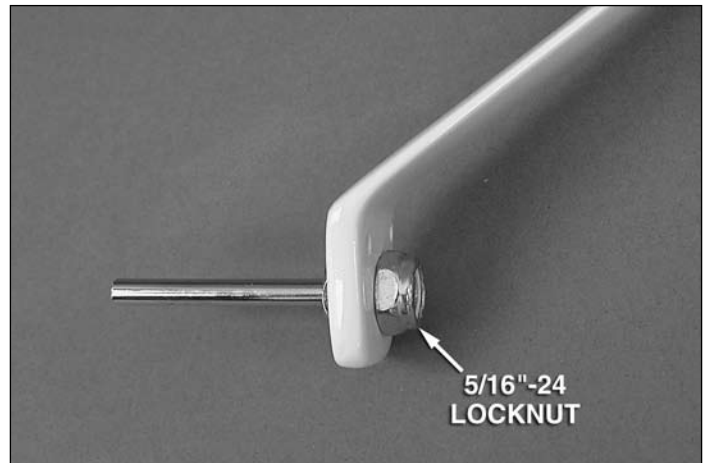

❑ 2. Attach the axles to the **main landing gear legs** with two 5/16"-24 locknuts. Slide a 3/16" [4.8mm] wheel collar onto each axle followed by a 3-1/2" [89mm] wheel and another 3/16" [4.8mm] wheel collar.



❑ 3. Temporarily install the wheel pants using four 4-40 x 1/2" [13mm] machine screws and four #4 flat washers.

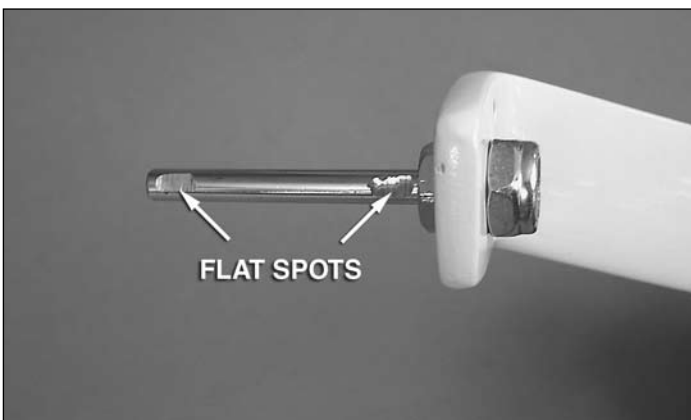

❑ 4. Position the wheels in the center of the wheel pants, slide the wheel collars against the wheel hubs, and mark the location of the screw holes in the wheel collars onto the axles. Remove the wheel pants from the gear and the wheels and collars from the axles and grind flat spots at your marks on the axles for the wheel collar screws using either a file or a rotary tool. Reinstall the wheels and collars onto the axles and secure the pants to the gear using four 4-40 x 1/2" [13mm] machine screws, four #4 flat washers, four #4 lock washers, and threadlocking compound. Use four 6-32 x 1/4" [6mm] SHCS and threadlocking compound to secure the wheel collars to the axles, being sure that you tighten the screws against the flat spots on the axles. The wheels should rotate freely between the wheel collars. Oil the axles if necessary.

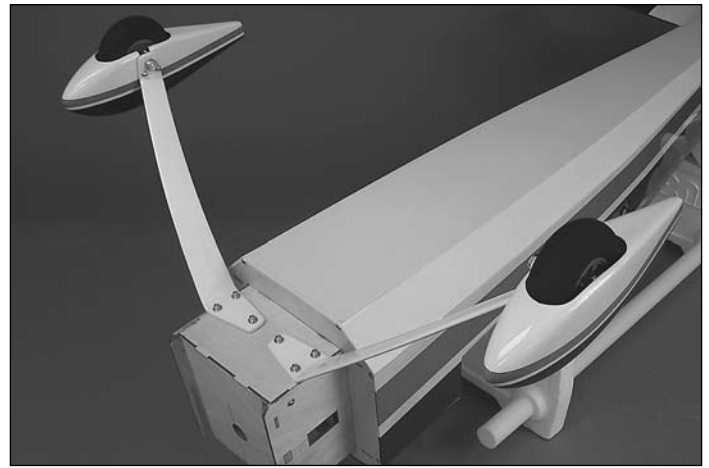

❑ 5. Attach the landing gear to the fuselage using six 6-32 x 1" [25mm] SHCS, six #6 flat washers, six #6 lock washers, and threadlocking compound.

Install Elevator Servos and Pushrods

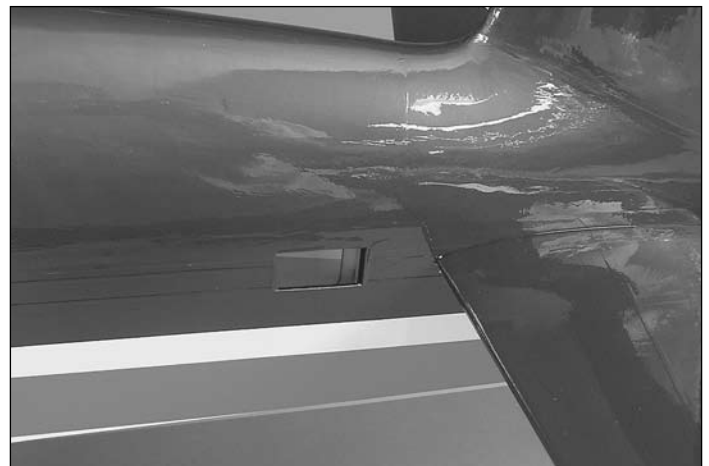

❑ 1. Trim the covering from the elevator servo bays leaving 1/8" [3mm] around the opening. Use a trim iron to seal down the covering around the edges of the servo bays.



❑ 2. Attach a 36" [914mm] servo extension to each elevator servo. Secure the servo extensions with the included heat-shrink tubing. Feed the servo extensions through the fuselage and install the servos into the servo bays with the

splines facing forward using the mounting hardware included with the servos. Be sure to harden the servo mounting screw holes with thin CA.

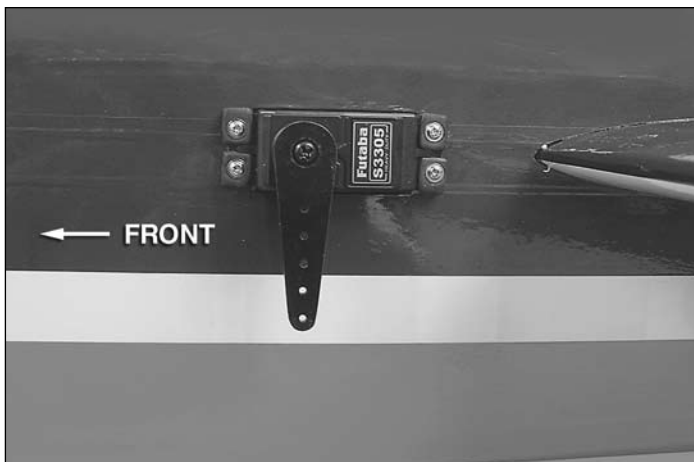

❑ 3. Attach a servo arm to each elevator servo with the arm pointing downward.



❑ 4. Just as you did with the ailerons, begin assembly of the elevator pushrods using two .095" x 12" [2.4mm x 305mm] pushrod wires threaded on one end, two 4-40 clevises, and two 4-40 nuts. Attach the clevis of each pushrod to the servo arms and use the pushrod as a guide to position the control horns onto the underside of the elevators. Secure the control horns to the elevators with eight #4 x 5/8" [16mm] sheet metal screws, being sure that you are drilling the screw holes through the plywood plates in the elevators. **Do not drill all the way through the elevators!** Center the elevators and use a solder clevis to mark where to cut the pushrod wires. Cut the wires, solder the clevises to the pushrods, and attach the pushrods to the elevators, securing the clevises with silicone clevis retainers.

Note: The Edge 540 1.60 ARF is set up for either forward (pull-pull system) or aft (pushrod system) rudder servo positions in order to offset ballast that may be required to balance the airplane. The rudder servos will be installed after the power system is put in place. After the installation of the power system, the current C.G. of the plane can be checked which will determine the optimum location of the rudder servos.

The following sections contain detailed instructions for mounting an O.S. 1.60 FX two-stroke glow engine, Fuji-Imvac BT-43 EI-2 gasoline engine, and the Great Planes RimFire 63-62-250kV outrunner brushless motor. Each specific installation only contains information relevant to that particular power system so you can skip directly to the section that matches your choice of power systems.

GLOW ENGINE INSTALLATION

Mount the Engine

The installation of a brand of glow engine other than the O.S. 1.60 FX should be similar to the procedure listed below for the O.S. model. A mounting template is provided on page 53 of this manual for installing the included Great Planes 1.20-1.80 nylon adjustable engine mount.

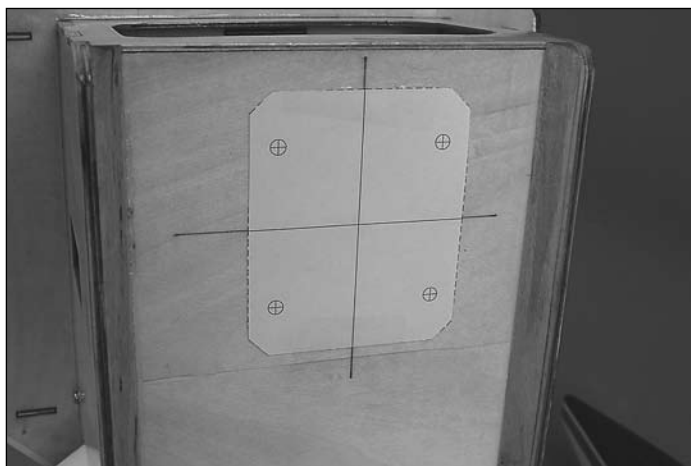

❑ 1. Cut the template out on page 53 for mounting the O.S. 1.60 FX glow engine. Use tape or spray adhesive to hold the glow engine mount template to the firewall. Align the vertical and horizontal lines on the template with the lines on the firewall.

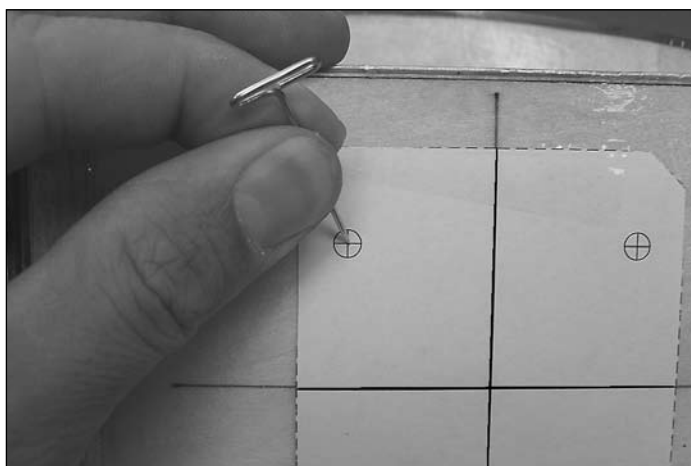

❑ 2. Use a large T-pin or a wire sharpened on the end to transfer each bolt hole mark on the template onto the firewall.

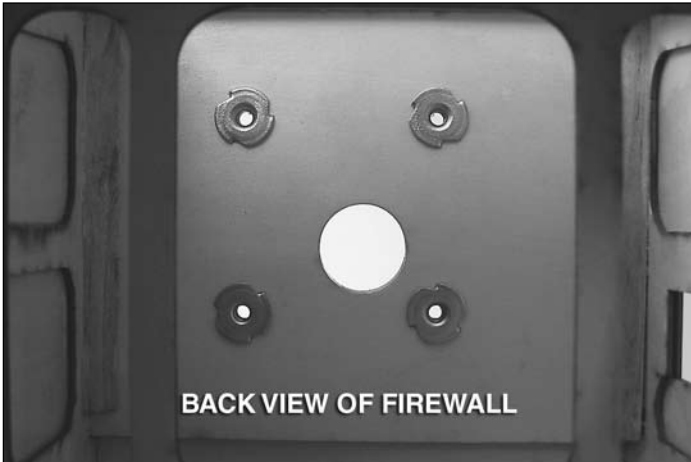
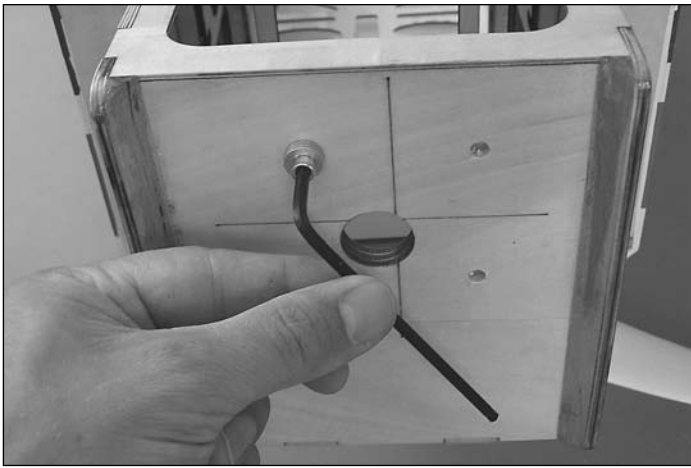

❑ 3. Use a 7/32" [5.6mm] bit to drill holes at the four marks you made on the firewall. To reduce tear-out, make pilot holes with a smaller bit first, then finish the holes with the 7/32" [5.6mm] bit. Insert a 8-32 blind nut into the back of each hole. Use a 8-32 x 1-1/4" [32mm] SHCS and a few #8 flat washers to draw the blind nuts tight against the back of the firewall.



❑ 4. Loosely install the 1.20 to 1.80 nylon engine mount to the firewall using four 8-32 x 1-1/4" [32mm] SHCS, four #8 flat washers, four #8 lock washers and threadlocking compound. The engine mount should be oriented so that the engine head will be on the right side of the plane.



❑ 5. Fit the engine onto the mount and slide the engine mount halves together against the engine crankcase. Remove the engine and tighten the engine mount screws. Reposition the engine onto the mount so that the front of the drive washer is 6-3/4" [171mm] from the firewall.

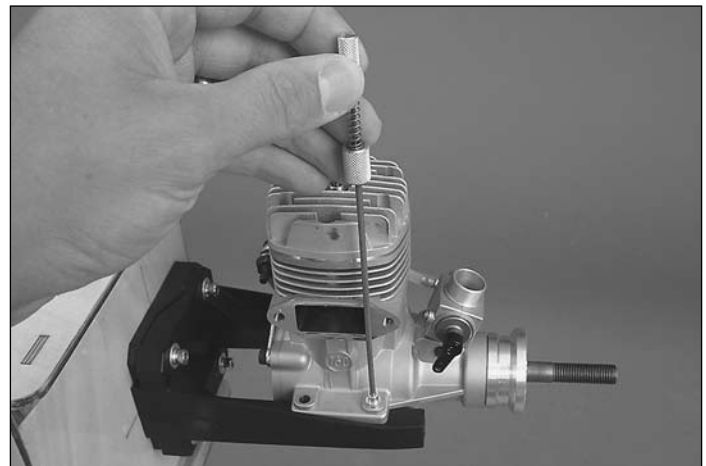

❑ 6. Use a Great Planes Dead Center™ Hole Locator or a small drill bit to mark the engine mounting holes onto the engine mount.

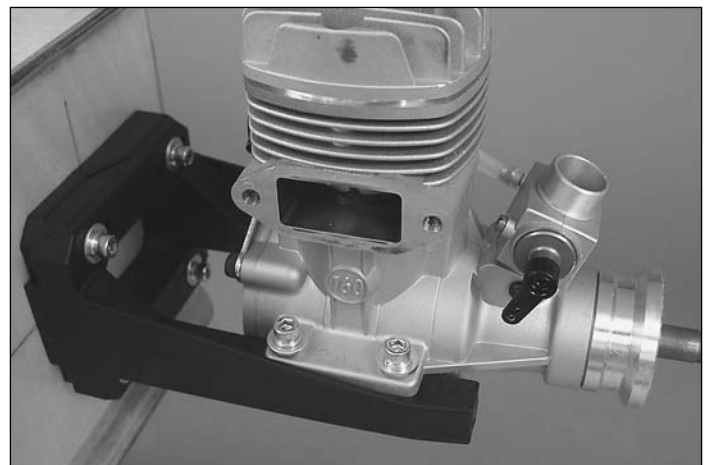

❑ 7. Drill 9/64" [3.6mm] holes at the marks you made and thread the holes using a 8-32 tap and handle. Install the engine onto the mount using four 8-32 x 1" [25mm] SHCS, four #8 flat washers and four #8 lock washers.

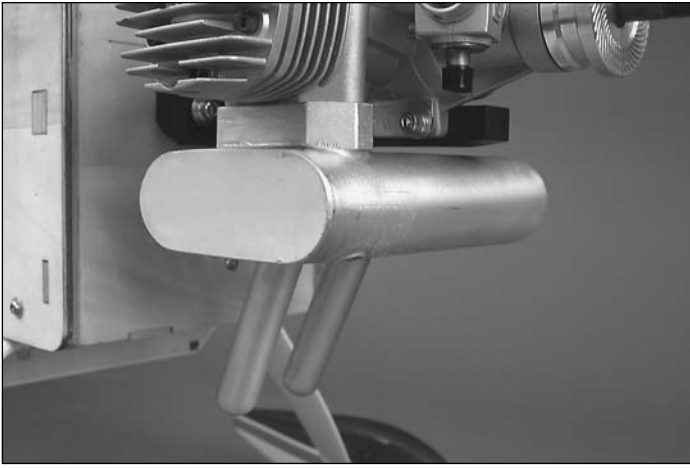

❑ 8. Attach a Pitts-style muffler to the engine using threadlocking compound.

Install the Fuel Tank (Glow)

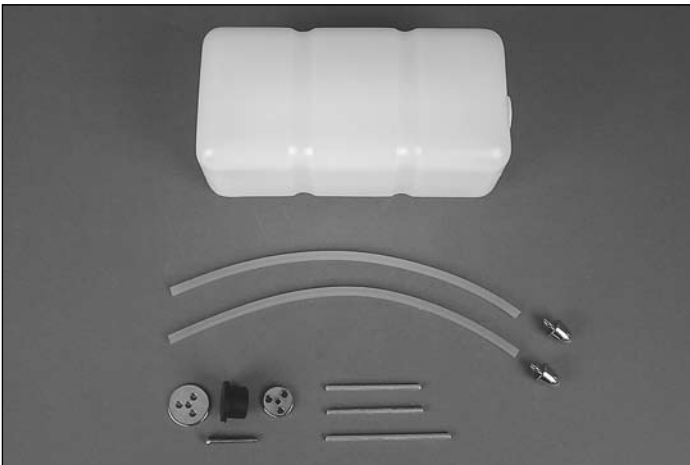

❑ 1. Locate the **fuel tank**. The hardware needed for the fuel tank assembly is inside of the tank. Remove the stopper and shake out the contents.

❑ 2. The fuel system for the Edge 540 1.60 ARF utilizes a three line system. There is a **fill line**, **carb line**, and **vent line** (to muffler). The fill line will allow fueling and defueling without removing the cowl. The fill line is optional and may be omitted if desired, or an optional Great Planes Easy Fueler Valve (not included) can be installed.

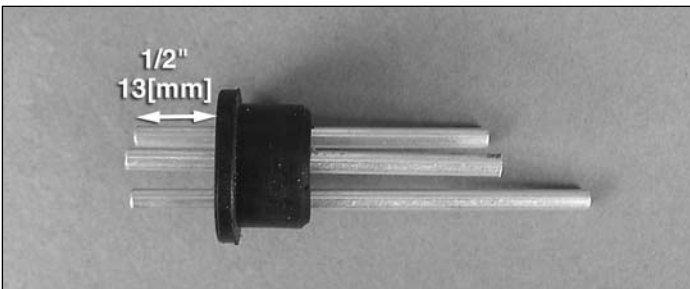

❑ 3. Use a hobby knife to open up the sealed third hole in the rubber stopper for the fill line. Slide the three aluminum **fuel tubes** into the rubber stopper so that the tubes extend beyond the front of the stopper by 1/2" [13mm]. If you are

installing a fueler valve or are omitting the fill line, install only two tubes into the stopper (one short tube and one long tube) leaving the third hole in the stopper sealed.

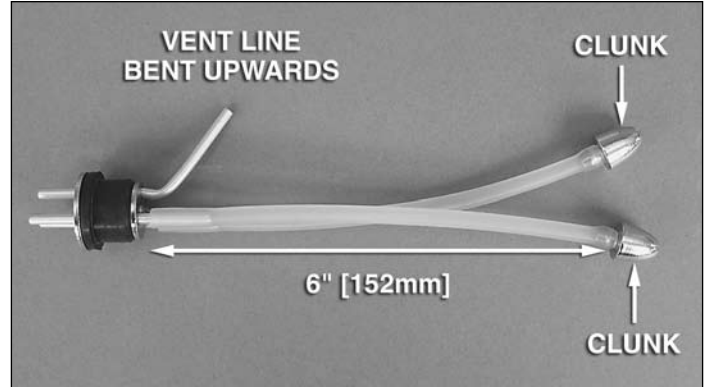

❑ 4. Install the metal plates on the front and back of the stopper and loosely thread the 3mm x 25mm phillips screw through the plates. Attach a silicone **fuel line** 6" [152mm] in length to each of the two short tubes in the stopper. The long tube (vent line) should be bent upward as shown (be careful not to kink the tube while bending it). Install the included fuel clunks onto the fuel lines.

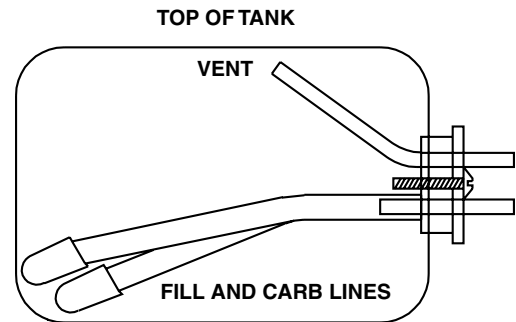

❑ 5. Insert the stopper into the tank and check the length of the carb line and fill line. The clunks should almost reach the back of the tank when the stopper is in place but be able to move around freely inside the tank. Adjust the length of the fuel line until the proper length has been reached. The vent line should almost reach the top of the tank. Once you are satisfied with the fit, secure the stopper using the phillips screw in the stopper assembly. Be careful not to over-tighten as the fuel tank could split.





❑ 6. Insert the fuel tank into the fuselage as shown with the neck of the tank pushed as far forward in the hole in the fuselage as it will fit. The vent line should be at the top of the tank. Secure the fuel tank inside the fuse by hooking two of the included rubber bands around the rubber band tabs as shown. Attach a length of fuel tubing approximately 9" [229mm] long to each of the fuel tank tubes.

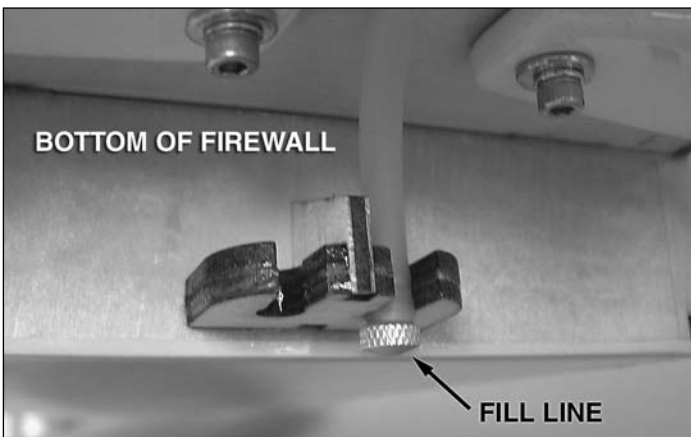
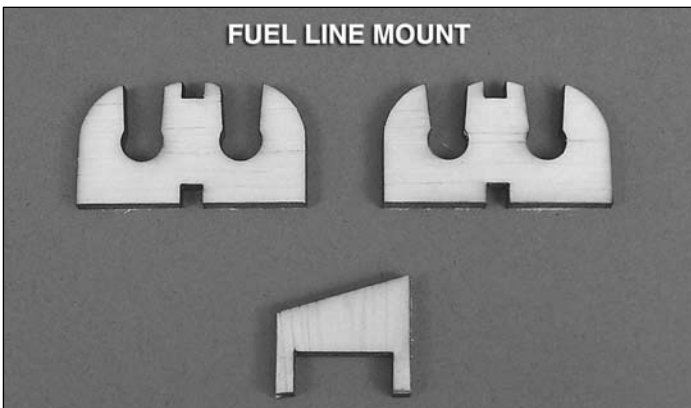

❑ 7. Cut the fuel tubing on the vent and carb lines to the necessary length and connect them to the engine. Locate the three pieces that make the optional **fuel line mount**. This part is used to hold the fill line at the bottom of the firewall (if an Easy Fueler valve is being used or some similar system, this part can be omitted). Glue the pieces together as shown. Use epoxy to fuel proof the part. Sand the bottom center of the firewall where the part will be glued with 220 grit sandpaper. Glue the piece in place and clip the fill line into one of the slots in the fuel line mount. The fill line can now be cut to length. A fuel line plug is provided for the fill line.

Install the Throttle Servo (Glow)



❑ 1. Attach the throttle servo to the firewall box as shown using the hardware included with the servo. Be sure to use thin CA in the servo mounting holes.

❑ 2. Cut three arms from a four arm servo arm and attach it to the throttle servo pointing down.

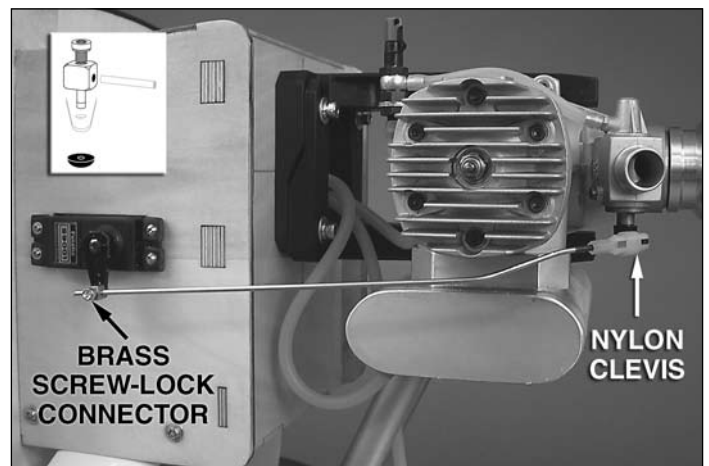

❑ 3. Install a brass screw-lock pushrod connector using a nylon retainer to the outer hole in the throttle servo arm. Loosely install a 4-40 x 1/8" [3mm] SHCS into the brass screw-lock connector. Install a nylon clevis and silicone clevis retainer 20 complete turns onto the .074" x 12" [1.9mm x 305mm] pushrod and bend the pushrod to fit from the throttle servo arm to the carburetor arm. When bending the rod, be sure there is clearance between the engine/muffler and the pushrod through the entire travel of the throttle servo. Metal to metal contact will cause radio interference. When satisfied, fit the pushrod through the screw-lock connector and connect the clevis to the carburetor arm. Slide the silicone clevis retainer to the end of the clevis and make any necessary adjustments to the pushrod length. Use your radio system to test the operation of the throttle servo. With all fine adjustments made, finish tightening the 4-40 x 1/8" [3mm] SHCS against the pushrod.

GAS ENGINE INSTALLATION

Mount the Engine

A template is provided on page 53 for mounting the Fuji-Imvac BT-43 EI-2 engine and pictures taken show the installation of this model gas engine. If another model engine is used, the engine manufacturer may provide a mounting template to use on the firewall. The gas engine installation will be similar for most model engines.

Because of the possibility of ignition engines creating radio noise, we use a plastic pushrod for the throttle servo installation. This isolates the engine and any radio noise from the servos. This is an IMPORTANT selection, and we cannot recommend strongly enough that you DO NOT change this pushrod to a metal pushrod. All radio equipment—including throttle servo, receiver battery, receiver on/off switch, servo leads—should be mounted at least 10" [254mm] away from anything related to the ignition/gasoline engine. Any material used between the engine and the radio equipment is STRONGLY recommended to be plastic, nylon, or otherwise non-metallic and nonconductive to minimize ignition noise transmission.

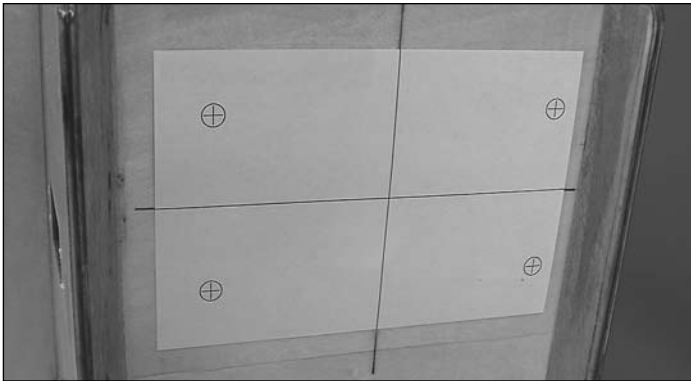

1. Cut the template out on page 53 for mounting the Fuji-Imvac BT-43 EI-2 engine. Use tape or spray adhesive to hold the template to the firewall. Align the vertical and horizontal lines on the template with the lines on the firewall.

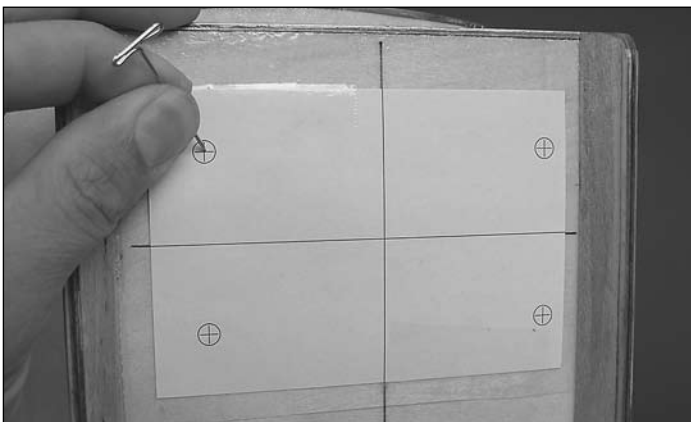

2. Use a large T-pin or a wire sharpened on the end to transfer each bolt hole mark on the template into the firewall.

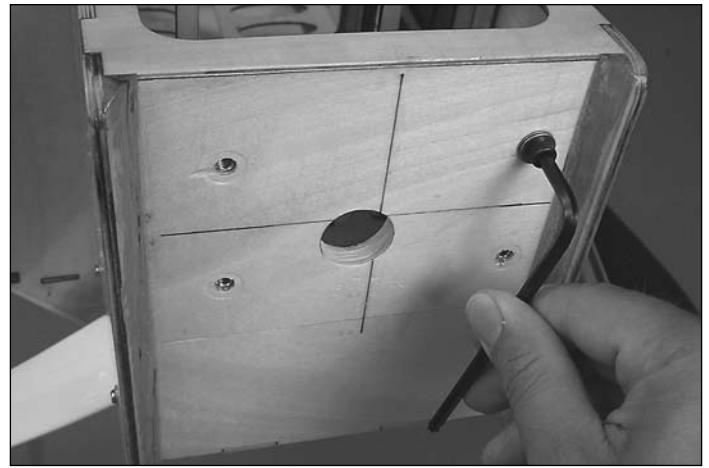

3. Measure the outer diameter of the boss on the blind nuts you will use to mount the engine (gasoline engine mounting hardware is not included). The 10-32 blind nuts we use will require a 1/4" [6.3mm] bit. Use the appropriate bit for your hardware to drill holes at the four marks you made on the firewall. To reduce tear-out, make pilot holes with a smaller bit first, then finish the holes with the correct diameter bit. Insert a 10-32 blind nut into the back of each hole. Use a 10-32 x 1-1/4" [32mm] SHCS and a few #10 flat washers to draw the blind nuts tight against the back of the firewall.

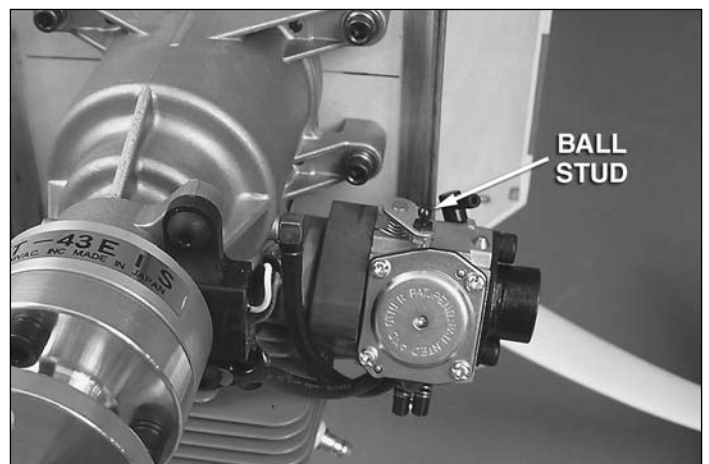

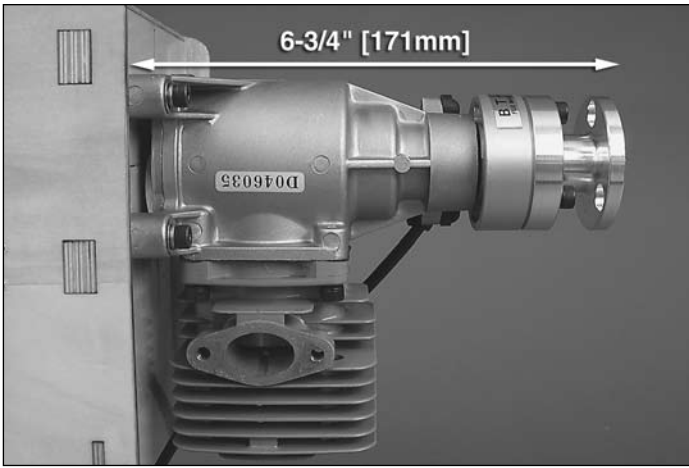

4. Attach the included ball stud to the throttle arm on the carburetor with a 2-56 nylon lock nut. Mount the engine inverted using four 10-32 x 1-1/4" [32mm] SHCS (not included), four #10 flat washers (not included), four #10 lock washers (not included), and threadlocking compound. The distance from the firewall to the front of the drive washer is 6-3/4" [171mm] when installing the Fuji-Imvac BT-43 EI-2 engine. This distance may vary slightly with other engine models. If installing another model engine, effort should be made to maintain a similar drive washer distance to the firewall.

Install the Fuel Tank (Gas)

The fuel line and stopper included with the Edge 540 1.60 ARF is **NOT** gasoline safe. Gasoline will degrade the rubber stopper and silicone fuel tubing supplied. You will need to purchase a gasoline safe stopper and gasoline safe tubing to use for the fuel system on this model. The **Sullivan #484 Gasoline/Diesel fuel tank conversion kit (SULQ2684)** works well for this.

1. Remove the stopper from the included fuel tank and replace it with a gas safe stopper as mentioned above.

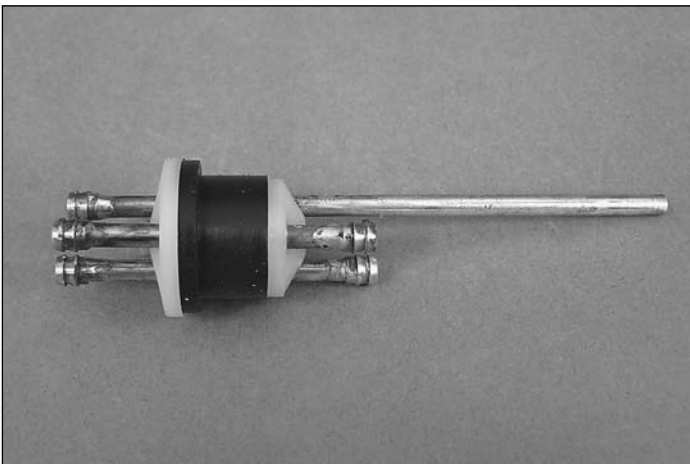

2. Assemble the stopper using Du-Bro #813 1/8" [3.2mm] I.D. fuel line barbs and 1/8" [3.2mm] brass tubing as shown. Solder the barbs to the brass tubing but be careful not to overheat the assembly as it could cause damage to the rubber stopper.

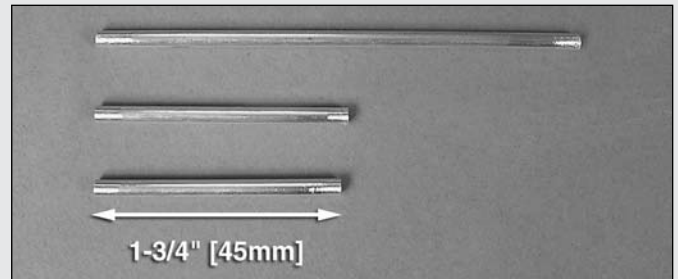

A. Cut one of the two brass tubes included with the Sullivan conversion kit in half (approximately 1-3/4" [45mm] pieces). Prepare the tubes for solder by scuffing up the ends with sandpaper and cleaning them with alcohol.

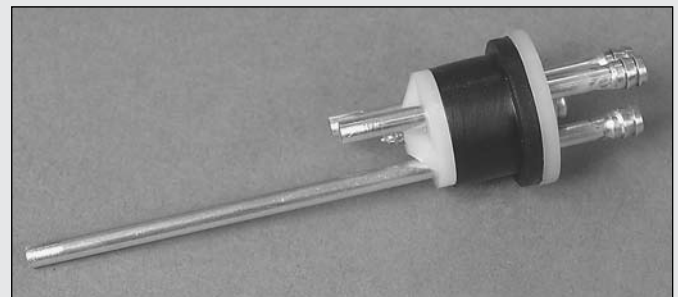

B. Assemble the stopper by inserting the tubes through the large stopper plate, stopper, and then the small stopper plate. Join the plates and stopper together using the screw that came with the conversion kit.

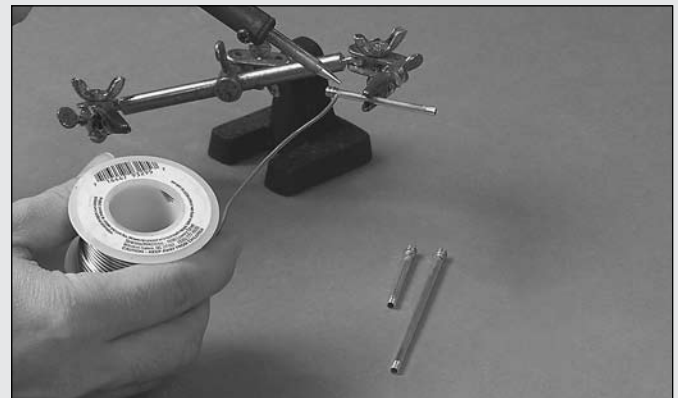

C. Solder a Du-Bro fuel line barb onto one end of each of the three tubes (be sure that the barbs are positioned in the correct direction on the tubes so that they will secure the fuel tubing when fitted in place). Slide the barbs in place and apply a small amount of solder to the joints between the barbs and the tubes. Solder will wick into the joints securing them in place. Be careful not to use too much solder as it could obstruct fuel flow inside the tubes.

Note: The item used in the picture above to hold the tubes is the X-Acto Extra Hands Double Clip (XACR4214).

D. Solder a barb onto the other end of each short brass tube.

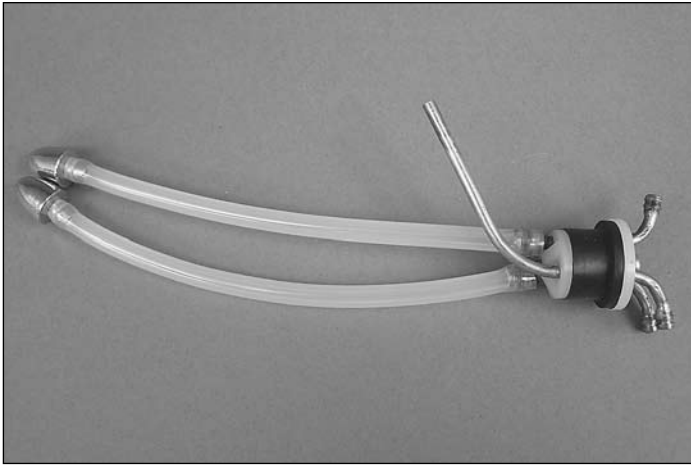

❑ 3. Carefully bend the tubes that exit the stopper as shown. Be sure that the lines do not have kinks at the bends. Attach a gasoline compatible fuel line such as Tygon 6" [152mm] in length to each of the two short tubes in the stopper. The long tube (vent line) should be bent upward. Install the included fuel clunks onto the fuel lines.

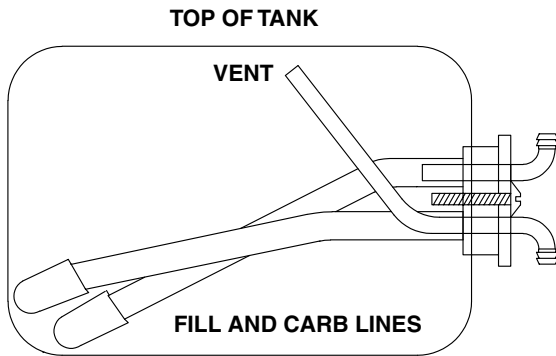

❑ 4. Insert the stopper into the tank and check the length of the carb line and fill lines. The clunks should almost reach the back of the tank when the stopper is in place but be able to move around freely inside the tank. Adjust the length of the fuel line until the proper length has been reached. The vent line should almost reach the top of the tank. Once you are satisfied with the fit, secure the stopper by tightening the screw in the stopper assembly. Be careful not to over tighten as the fuel tank could split.

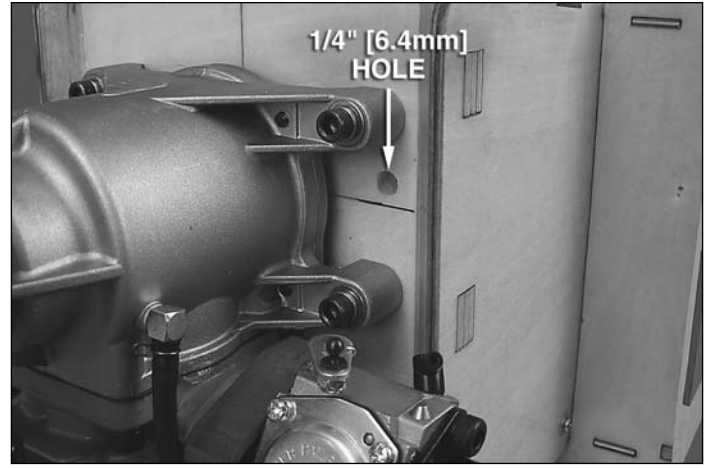
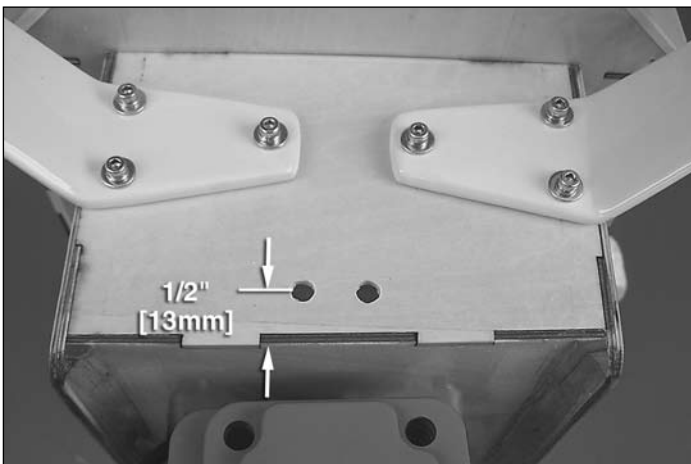

❑ 5. Measure and mark 1/2" [13mm] from the front of the firewall on the bottom of the motor mount box for the fill and vent lines and drill a 1/4" [6.4mm] hole at your marks. Make a mark on the firewall near the carburetor for the carb line and drill another 1/4" [6.4mm] hole.

❑ 6. Attach approximately 10" [254mm] of gas compatible fuel line to the fill line, carb line, and vent line.

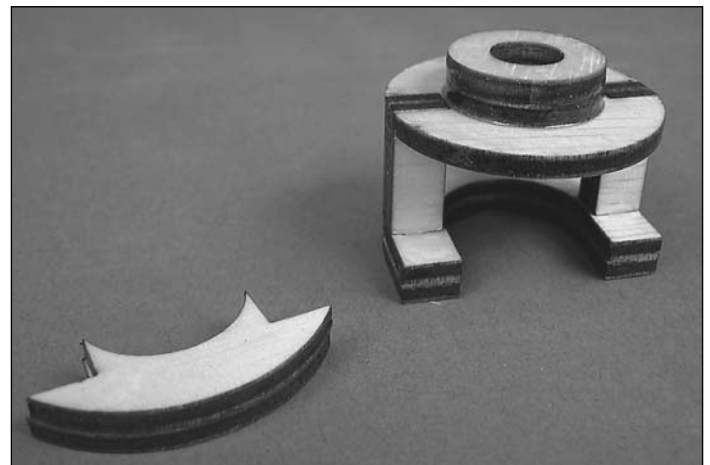

❑ 7. Locate the **gas fuel tank support** pieces. Glue the pieces together as shown. Be sure the sides of the pieces are glued together flush. When complete, use epoxy to fuel proof the two assemblies.

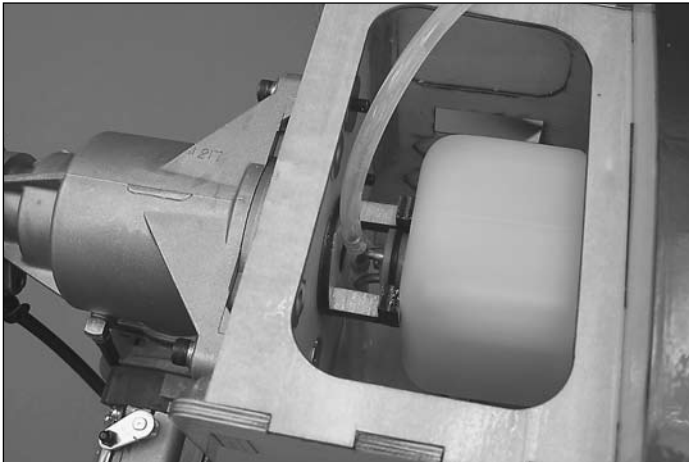
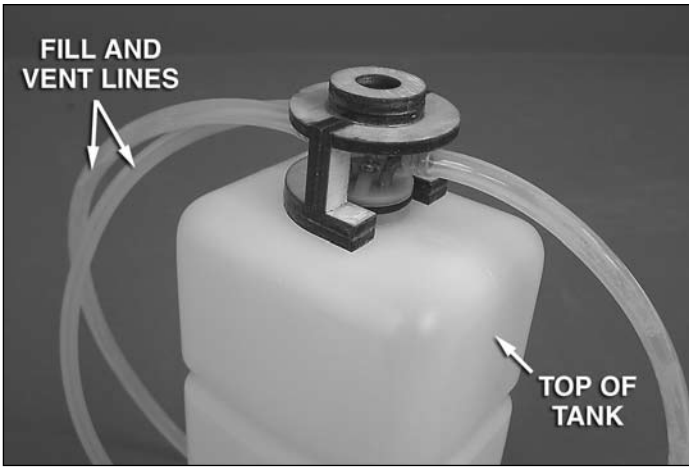

❑ 8. Feed the fill and vent lines through the gas fuel tank support bottom piece and fit it around the fuel tank neck as shown. Insert the fill and vent lines through the holes you drilled in the bottom of the motor mount box and slide the tank through the second former in the fuselage. Fit the gas fuel tank support bottom piece into the hole in the firewall.

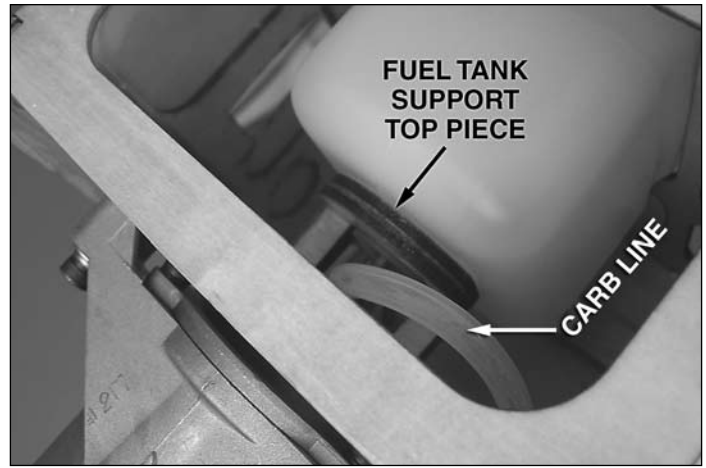

❑ 9. Secure the fuel tank inside the fuse by hooking two of the included rubber bands around the rubber band tabs as shown. Route the carb line through the hole you drilled in the firewall, cut it to the correct length and connect it to the carburetor. Glue the gas fuel tank support top piece to the bottom piece, which will capture the fuel tank neck in place.

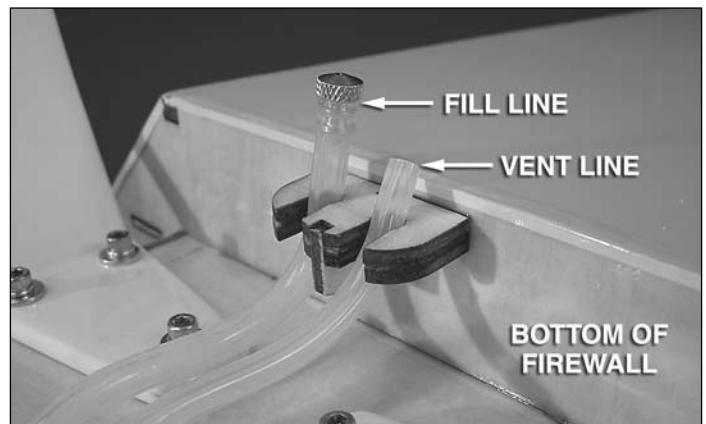
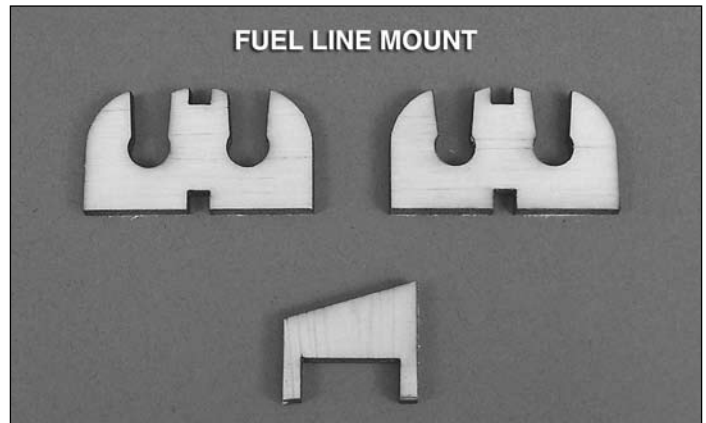

❑ 10. Locate the three pieces that make the optional **fuel line mount**. This part is used to hold the fill and vent lines at the bottom of the firewall (if an Easy Fueler valve is being used or some similar system, this part can be omitted). Glue the pieces together as shown. Use epoxy to fuel proof the part. Sand the bottom center of the firewall where the part will be glued with 220 grit sandpaper. Glue the piece in place and clip the fill and vent lines into the slots in the fuel line mount. These lines can now be cut to length. A fuel line plug is provided for the fill line (be sure that you insert the fuel line plug into the fill line).

Install the Throttle Servo (Gas)



Since most gas engine installations will require the rudder servos to be installed in the aft location to minimize additional ballast when balancing the model, the throttle servo can be installed into one of the unused forward rudder servo bays. If you determine that your engine installation requires the rudder servos to be installed in the forward position, an alternative throttle servo tray is provided. The tray can be glued or screwed on either side of the forward rudder servo bays. The additional pieces shown in the picture should be glued to the underside of tray at the ends of the throttle servo opening for the servo mounting screws. The remainder of the throttle servo installation steps will still apply.

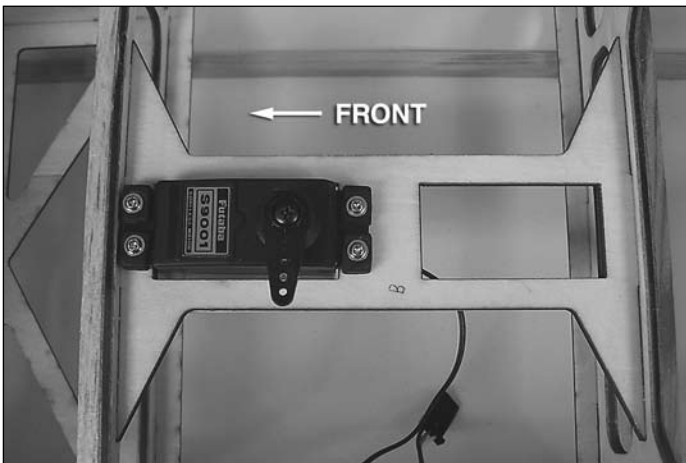

1. Place your throttle servo into the forward rudder servo bay as shown. Drill 1/16" [1.6mm] holes to mount the servo. Install the servo into the servo bay using the hardware included with the servo. Be sure to apply thin CA to the holes to harden the wood. Center the servo with your radio system (depending on the location of the receiver, a 6" [152mm] servo extension may be needed). Attach a servo arm to the servo, securing it with the servo arm screw. The servo arm should be on the same side as the carburetor on your engine.

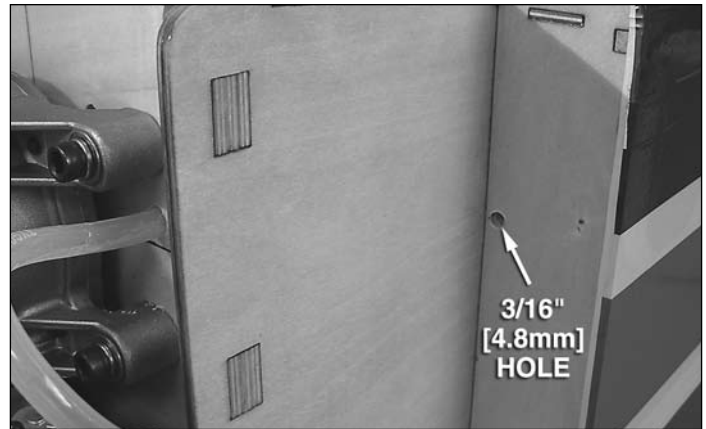

2. Determine the location of the throttle pushrod based on the position of the throttle arm on the carburetor. Drill a hole through the firewall for the throttle pushrod using a long, 3/16" [4.8mm] drill bit. If you do not have a long drill bit, you may need to temporarily remove the engine in order to drill the hole.

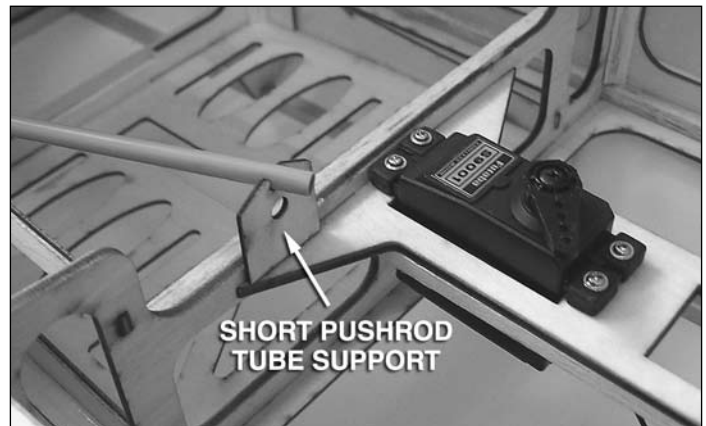
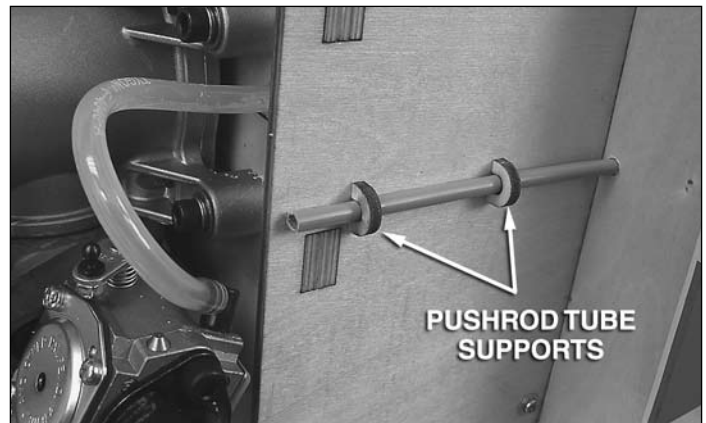

3. Insert the outer pushrod tube through the hole in the firewall and slide it through the formers in the fuselage toward the servo arm on your throttle servo. Mark and cut the pushrod tube to the necessary length. Use sandpaper to scuff the tube where it will be glued to the firewall and the **throttle pushrod tube supports**. Reinstall the tube into the plane and glue the forward end to the firewall. Long pushrod supports are provided and can be cut to length and used where needed. Clip the short throttle pushrod tube support near the aft end of the tube. Use the pushrod tube support to align the outer pushrod tube level with the throttle servo arm. Glue the pushrod tube support to the fuselage former as shown and glue the tube to the support.

USE THE FOLLOWING IMAGES FOR STEPS 4 AND 5

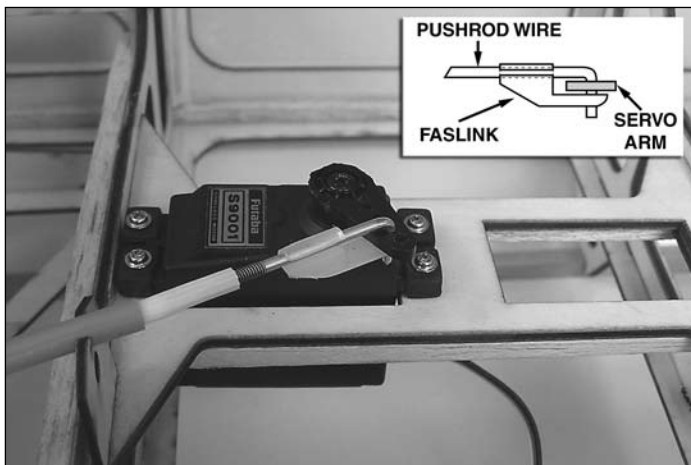
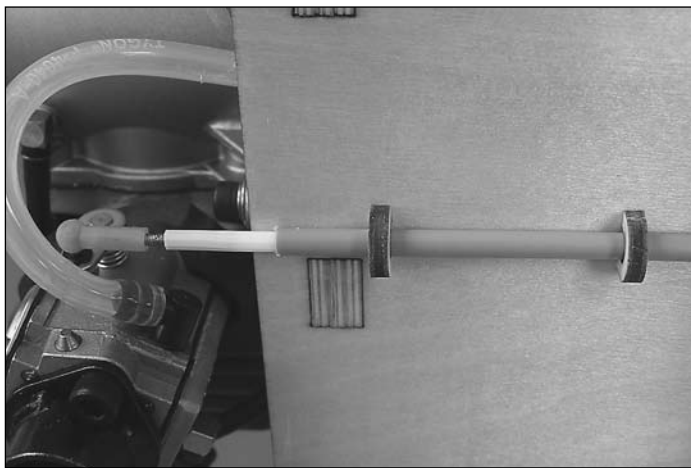
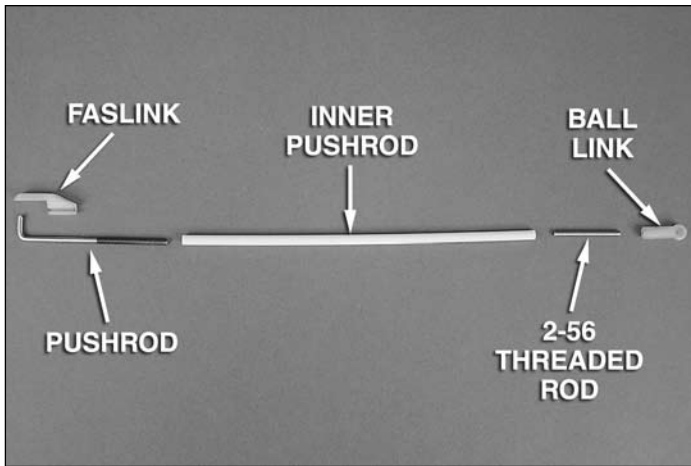

approximately 1/2" [13mm]. Mark where the 6" [152mm] pushrod needs to be bent in order to align with the second to outer hole of the throttle servo arm (be sure that the arm is positioned so it will open and close the carburetor correctly when the pushrod is installed). Bend the 6" [152mm] pushrod at the mark you made and cut off the excess wire 1/4" [6mm] beyond the bend. Enlarge the second to outer hole of the throttle servo arm using a 5/64" [2mm] drill bit. Connect the pushrod to the throttle servo using a nylon FasLink. Test the operation of the throttle servo and make any necessary adjustments to the pushrod length.

Install the Ignition Equipment (Gas)

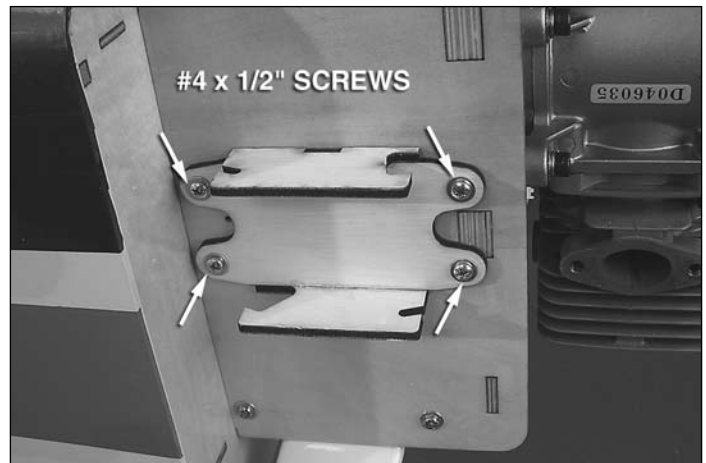

❑ 4. Thread the 2-56 x 1" [25mm] threaded rod approximately 3/8" [9.5mm] into one end of the nylon inner pushrod. Thread a nylon ball link onto the other end of the threaded rod. Insert the inner pushrod into the outer pushrod tube and connect the ball link onto the carburetor throttle arm. Mark where the inner pushrod will need to be cut to length.

❑ 5. Remove the inner pushrod tube and cut it to length at the mark you made and re-install it. Press the ball link onto the carburetor throttle arm ball. Cut the included .075" x 12" [1.85mm x 305mm] pushrod to approximately 6" [152mm] long to make it easy to work with inside the fuselage. Thread the 6" [152mm] piece of pushrod into the nylon inner pushrod

❑ 1. Locate the plywood **ignition module mount** pieces. Glue them together as shown and fuel proof the assembly. Place the mount onto the motor mounting box side that is opposite the carburetor. Mark the locations for the four mounting holes. Drill 3/32" [2.4mm] holes at your marks. Thread a #4 x 1/2" [13mm] screw into each hole and back it out. Apply a couple drops of thin CA to each hole to harden the wood. Screw the mount to the firewall using four #4 x 1/2" [13mm] screws and four #4 flat washers.

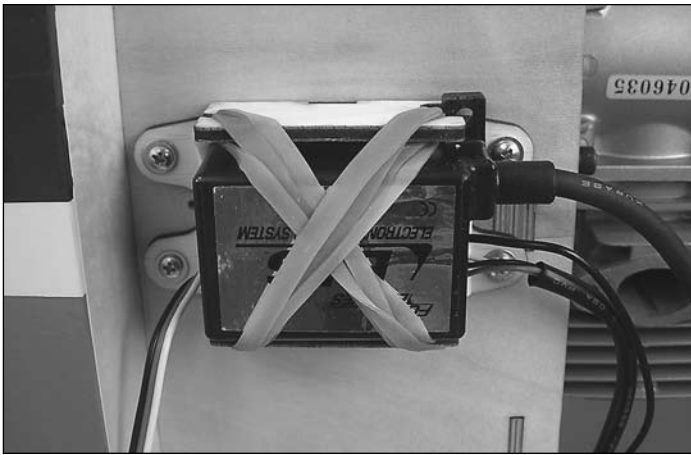

❑ 2. Cut a piece of 1/4" [6mm] foam rubber (not included) to line the bottom of the ignition module mount. Position the ignition module onto the mount and use rubber bands to secure it to the mount. **Note:** Different models of engines may require an alternative method of mounting the ignition equipment depending on the size of the components, length of wires, and engine manufacturer recommendations.

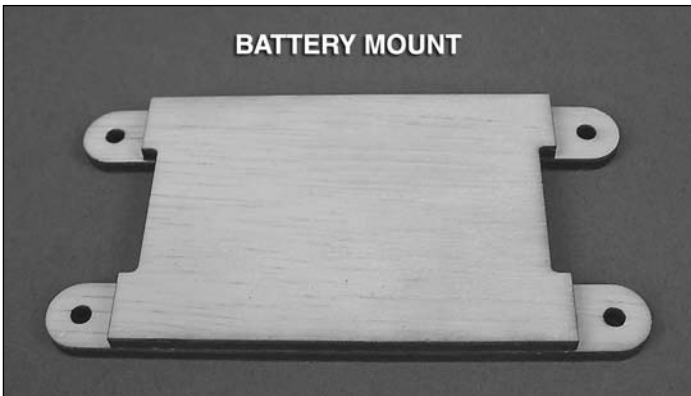

❑ 3. Locate the three **ignition battery mount** pieces. Glue the two long pieces flush with the long sides of the large piece and centered left and right. Fuel proof the assembly.

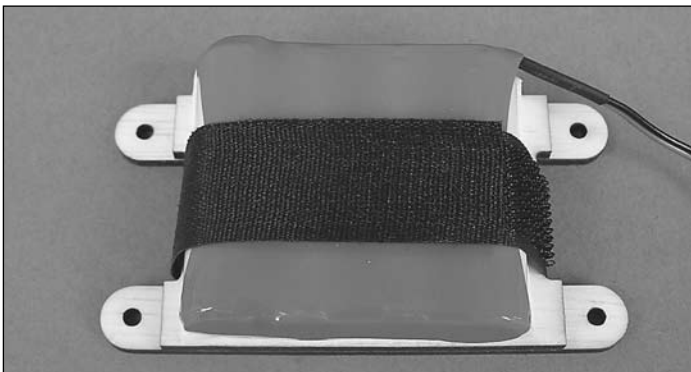
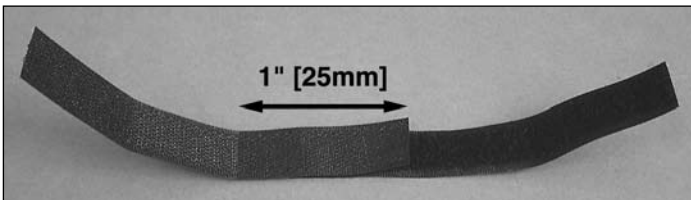

❑ 4. Cut a piece of foam rubber to fit your ignition battery pack. Make a hook and loop strap to fit your ignition pack by

overlapping the mating ends of the included hook and loop material by approximately 1" [25mm]. The total length of the strap you make will be determined by the size of your pack. Place the foam rubber onto the ignition battery mount and use the hook and loop strap to secure the battery to the mount.

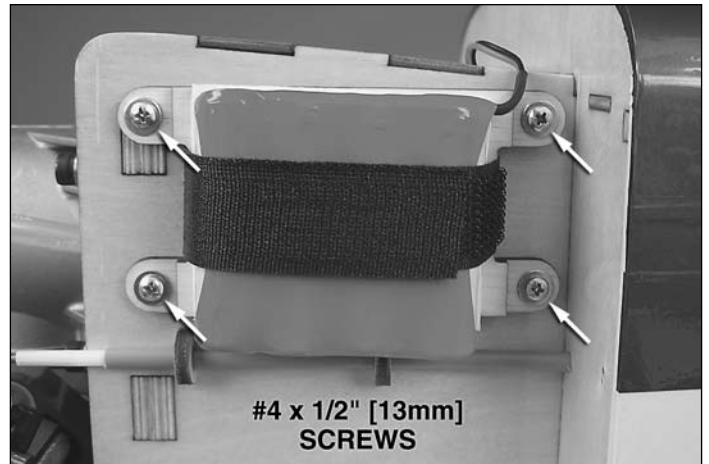

❑ 5. Place the mount onto the motor mounting box side and mark the locations for the four mounting holes. Drill 3/32" [2.4mm] holes at your marks. Thread a #4 x 1/2" [13mm] screw into each hole and back it out. Apply a couple drops of thin CA to each hole to harden the wood. Screw the mount to the firewall using four #4 x 1/2" [13mm] screws and four #4 flat washers. Be sure that the battery pack is properly secured to the battery mount. The mount can also be installed so the hook and loop strap is oriented vertically.

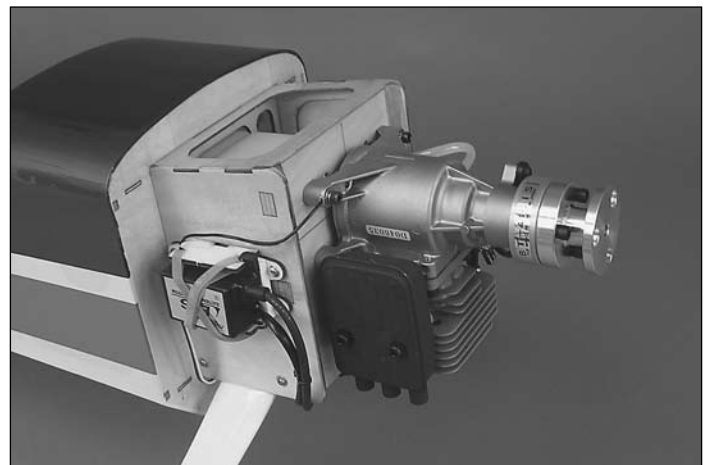

❑ 6. Install the muffler onto the engine if you have not done so yet. Connect the spark plug wire to the engine, ground wire to the engine crankcase (see engine manual) and the ignition module wire lead to the pick up sensor. Mount your ignition battery switch (or engine kill switch) and charge jack near the front of the fuselage (test fit the cowl over the engine to make sure the position of the switch and jack will not interfere with it). If you plan to install hardware (not included) for operating the engine choke, do so now. Access to the choke will need to be made when installing the cowl.

BRUSHLESS MOTOR INSTALLATION

Mount the Motor

The installation of a brand of out-runner brushless motor other than the Great Planes RimFire 63-62-250KV should be similar to the procedure listed below for the Great Planes model. Be sure to maintain the correct prop adapter distance from the firewall regardless of which motor you choose to install. A mounting template is provided on page 53 of this manual for installing the Great Planes Extra Large Brushless Motor mount.

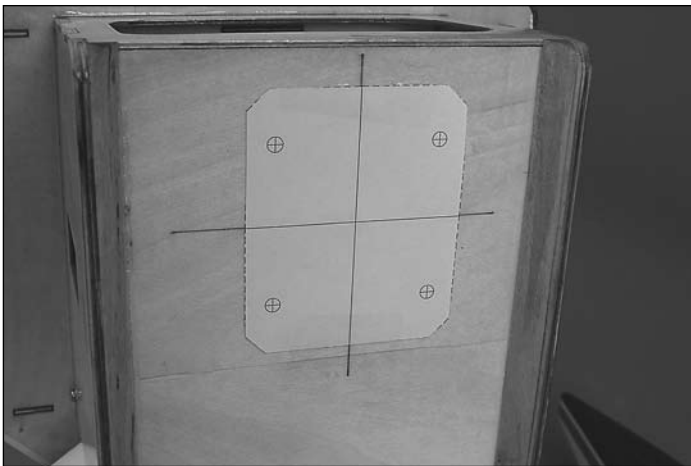

❑ 1. Cut the template out on page 53 for mounting the Great Planes Extra Large Brushless Mount. Use tape or spray adhesive to hold the template to the firewall. Align the vertical and horizontal lines on the template with the lines on the firewall.

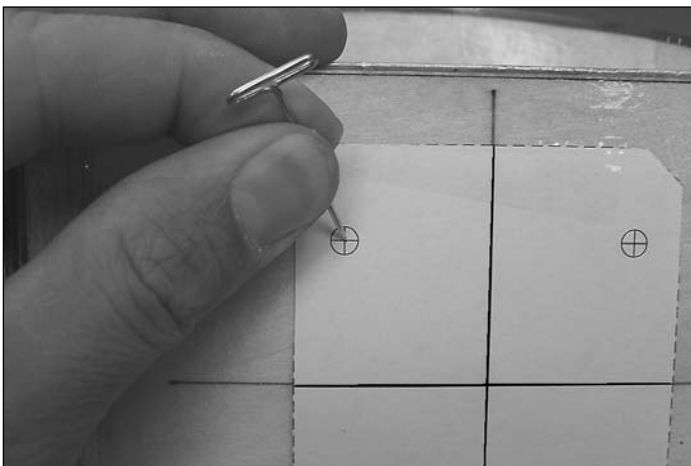

❑ 2. Use a large T-pin or a wire sharpened on the end to transfer each bolt hole mark on the template into the firewall.

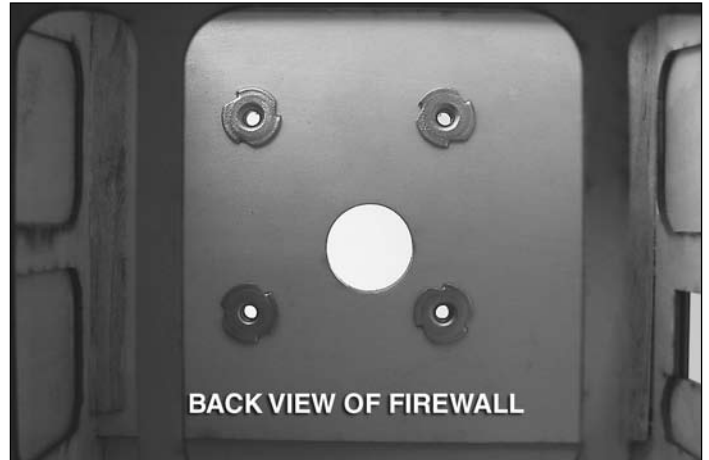
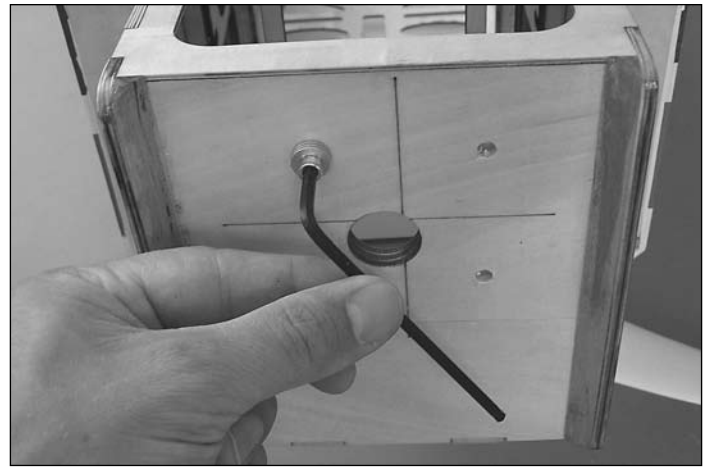

❑ 3. Use a 7/32" [5.6mm] bit to drill holes at the four marks you made on the firewall. To reduce tear-out, make pilot holes with a smaller bit first, then finish the holes with the 7/32" [5.6mm] bit. Insert a 8-32 blind nut into the back of each hole. Use a 8-32 x 1" [25mm] SHCS and a few #8 flat washers to draw the blind nuts tight against the back of the firewall.



❑ 4. Attach the motor to the brushless motor mount using the included four 3 x 8mm machine screws, four 3mm flat washers, and **threadlocking compound**. You may need to remove the brass collar to fit the motor to the mount. Be sure to replace the collar after the motor is installed. If you haven't done so already, install the prop adapter to the front of the motor using the hardware included with the motor and **threadlocking compound**.

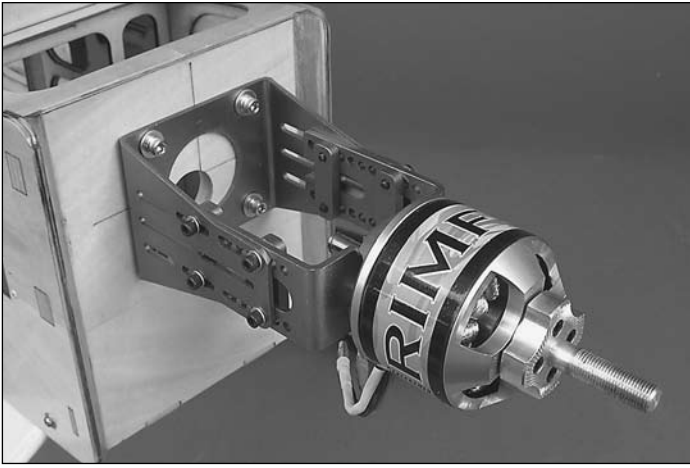

❑ 5. Attach the mount to the firewall using four 8-32 x 1" [25mm] SHCS, four #8 flat washers, four #8 lock washers and threadlocking compound.

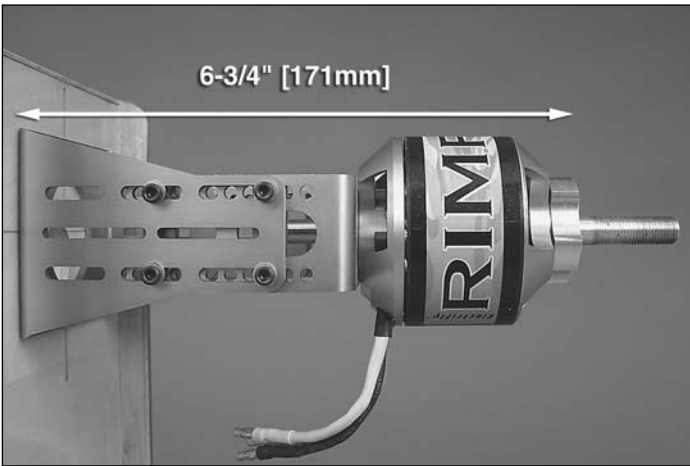

❑ 6. Loosen the motor mount assembly screws and adjust the mount halves so that the face of the prop washer is 6-3/4" [171mm] from the firewall. **Use threadlocking compound and securely tighten all screws.** Be sure to not inadvertently create any additional down thrust when adjusting the mount halves.

Install the Battery and ESC Trays



❑ 1. Locate the two **brushless battery tray** pieces.

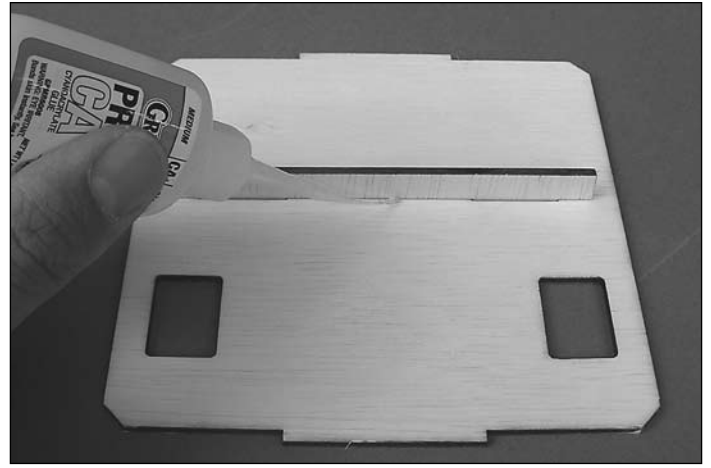

❑ 2. Glue the brushless tray cross brace to the battery tray as shown.

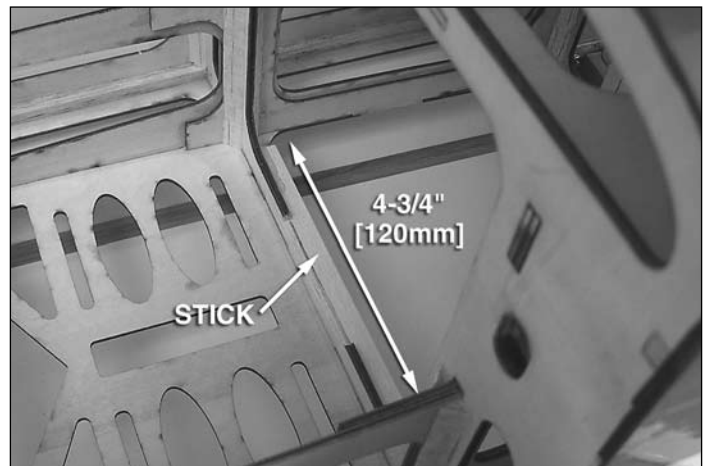

❑ 3. Cut a 4-3/4" [120mm] long piece from the 1/4" x 1/4" x 6" [6 x 6 x 150mm] hardwood stick securely. Glue the stick in front of the second former in the location shown.

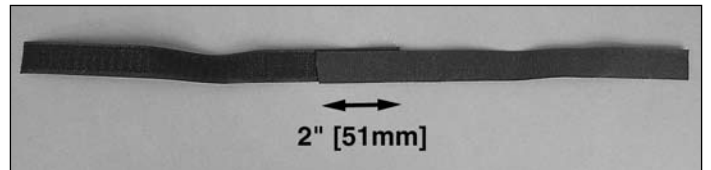

❑ 4. Brush on a coat of epoxy down the center of the battery tray. The epoxy will provide a smooth surface for self-adhesive hook and loop material (not included). Make a battery strap

out of the included non-adhesive hook and loop material by overlapping two halves by 2" [51mm]. The total length of the strap will be determined by the size and quantity of the LiPo packs you are using. We suggest starting out with a strap that is approximately 18" [457mm] long. This length will accommodate the largest batteries that will fit into the Edge. Feed the strap through the strap holes in the battery tray.



❑ 5. The battery tray fits into place by inserting the tab at the forward end of the battery tray into the slot in the first former in the fuselage. The aft tab on the battery tray fits into the notch in the second former as shown. Thoroughly glue the tray into the fuselage by running a bead of epoxy or thick CA on the tabs on the tray, the slots, and along the top of the hardwood stick you installed in step 3. Being sure that the tray is fully seated against the hardwood stick, run a bead of glue along each side of the tray where it meets the fuse. **Confirm that the tray is securely glued in place.**

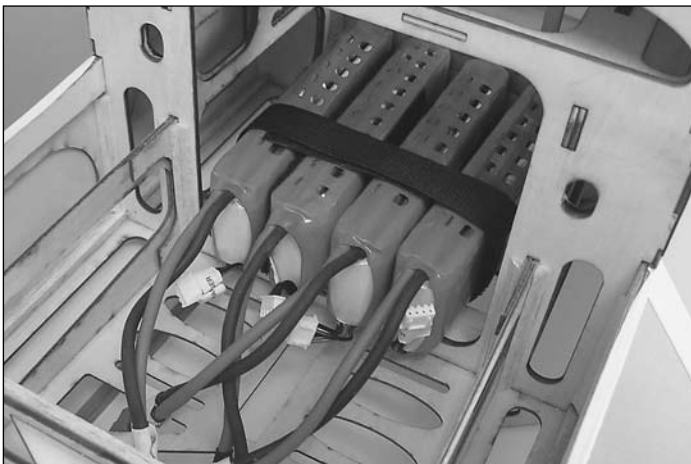

❑ 6. When it is time to install the batteries into the plane, apply a strip of self-adhesive hook and loop material to the bottom of the battery packs and to the battery tray. Slide the batteries in place and use the strap to hold them securely.

IMPORTANT: Before experimenting with different battery combinations and connecting multiple battery packs with adapter plugs, refer to the **"Battery Precautions"** on page 43.



❑ 7. Locate the plywood **ESC tray** pieces.

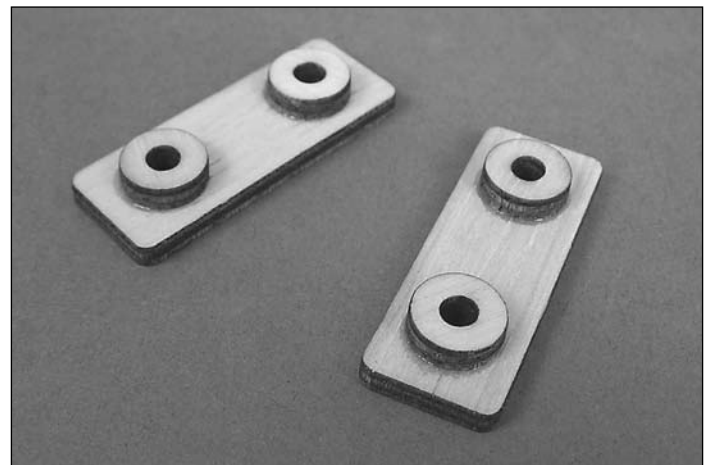

❑ 8. Glue the blind nut spacers to the rectangular mounting plates. Be sure that the holes in the spacers align with the holes in the mounting plates.



❑ 9. Fit the tabs on the side pieces into the slots in the tray and glue them in place. Cut two small pieces from the triangle stock and glue them in place as shown.

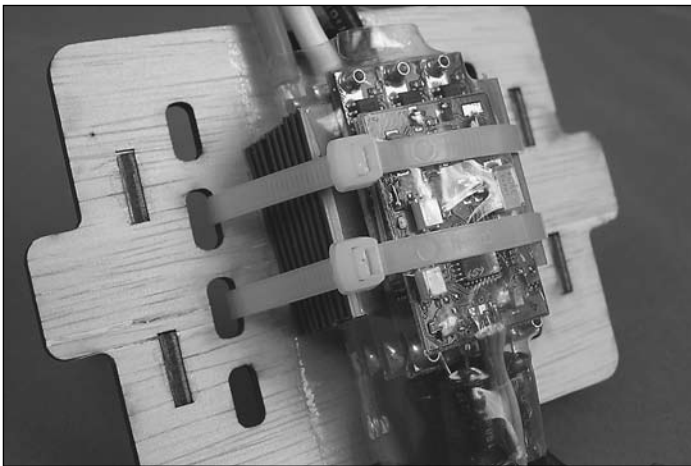
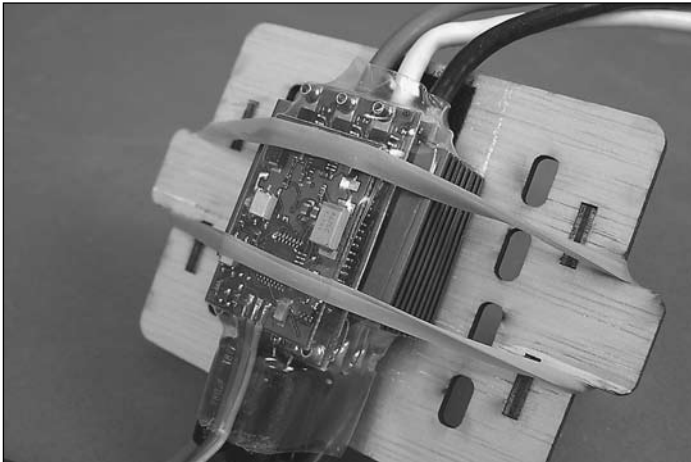
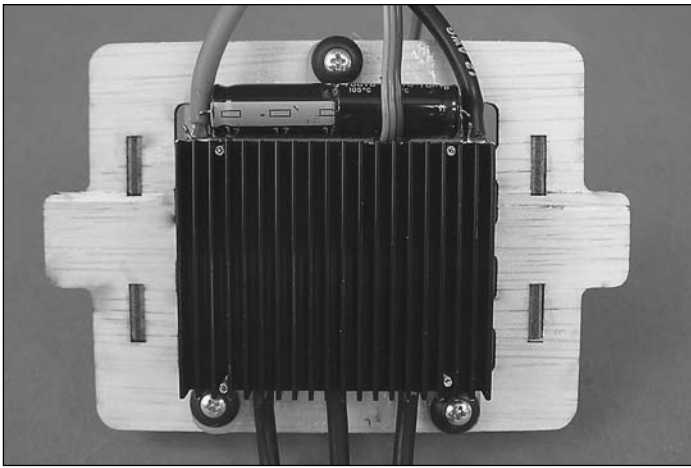

□ 10. If the ESC you are using has mounting tabs, the ESC can be screwed in place onto the tray as shown. If not, use self-adhesive hook and loop material (not included) and rubber bands or tie straps to secure it to the tray. Apply a coating of epoxy to the underside of the ESC tray. The epoxy will improve the adhesion of the hook and loop material. When the epoxy has cured completely, attach your ESC to the underside of the ESC tray with self-adhesive hook and loop material. Depending on the size of the ESC you are using, it can be properly secured to the tray using a rubber band or the included 8" [200mm] tie straps. Be certain the ESC is securely mounted **before** the motor is run and flown.

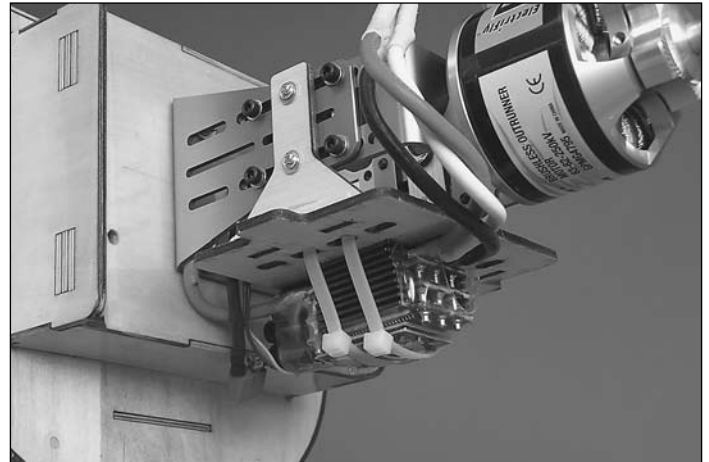
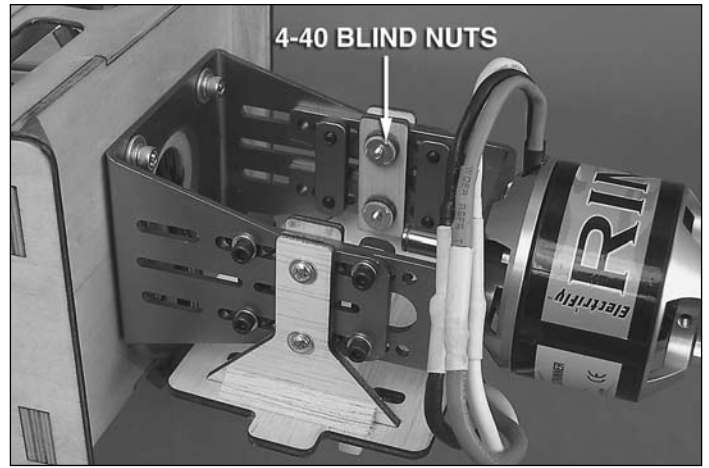

□ 11. Insert a 4-40 blind nut into each of the four blind nut spacers. Attach the ESC tray to the aluminum brushless motor mount using four 4-40 x 3/4" [19mm] machine screws, four #4 flat washers and **threadlocking compound**. The screws should pass through the ESC tray side pieces, through a set of unused holes in the aluminum motor mount and into the blind nuts in the mounting plates. If the aluminum blocks used to hold the two aluminum motor mount halves together interfere with the plywood ESC mounting plates, you may need to remove the screws holding the mount halves together and move the aluminum blocks further away from the center. If necessary, install a 12" [305mm] servo extension to the ESC and secure it with heat shrink tubing. Connect the motor leads to the ESC. Now would be a good time to confirm the correct rotation of the motor using the radio system. **DO NOT INSTALL A PROPELLER ONTO THE MOTOR AT THIS TIME!** See the ESC manual for operating instructions. If the motor rotates in the wrong direction, simply unhook any two motor lead wires and swap their position. The motor should rotate counterclockwise when looking at it from the front. Be sure the motor leads are secured out of the way from the motor.

INSTALL THE RUDDER SERVOS

These two sections refer to installing the rudder servos in the forward position utilizing a pull-pull system and installing them in the aft position utilizing pushrods. If you have not yet decided which installation is necessary for your power system, consider the following for each type:

GLOW ENGINE

The weight of the O.S. 1.60 FX and Pitts muffler (39 oz [1106 g]) require that the rudder servos be installed in the forward position utilizing a pull-pull rudder system to balance the airplane at the recommended C.G. with the addition of extra ballast at the nose of the plane. If you are installing an engine that is heavier than the 1.60 FX, you may wish to check the current C.G. of the plane before proceeding.

GAS ENGINE

Most gas engine installations (including the Fuji-Imvac 43 El-2 engine) will require the rudder servos to be installed in the aft position. We suggest checking the balance before you proceed with the rudder servo installation if you are installing a lighter engine. The Fuji-Imvac BT-43 El-2 engine weighs 64 oz [1814 g] with the muffler, El unit, prop bolt, and prop washer (also consider the weight of the ignition battery pack you will be using).

BRUSHLESS MOTOR

Battery size and voltage will ultimately determine the optimum rudder servo position. We suggest checking the balance of the airplane at this time before proceeding with the rudder servo installation.

CHECK THE CURRENT BALANCE OF THE MODEL

Check the balance of the model by installing the wing onto the fuse, sliding the cowl over the firewall and taping it in place (it is okay if the cowl is not on the fuselage straight), and installing your propeller and spinner. These components only need to be loosely installed and are only for checking balance of the plane. Follow the balancing procedure described on page 45 of this manual. With the C.G. set at the recommended distance, experiment with the rudder servos by placing them both into the forward rudder servo tray, as well as resting them on the tail of the plane near the leading edge of the stabilizer. The receiver battery pack should also be placed either onto the radio tray (refer to "Install the Radio System" on page 43), or the motor mousing box.

Install the Rudder Servos in the Forward Position

RECOMMENDED INSTALLATION FOR GLOW ENGINES

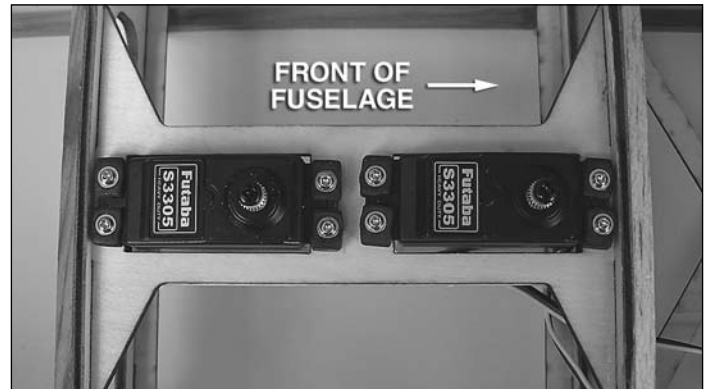

1. Position the rudder servos into the servo tray as shown. Drill a 1/16" [1.6 mm] hole through the mounting holes of each servo. Install and remove a mounting screw from each hole and apply a couple drops of thin CA into the holes to harden the wood. After the glue has hardened, install the servos into the openings with the servo splines towards the front of the plane using the hardware that came with your servos. Center the servos with your radio system.

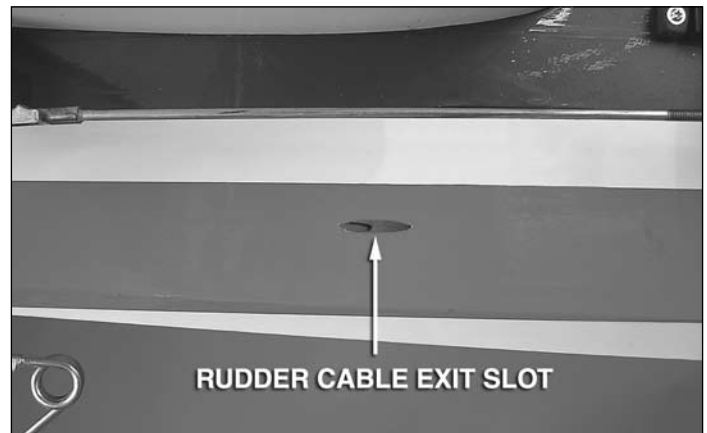

2. Trim the covering from the rudder cable exit slots that are located beneath the horizontal stabilizer.

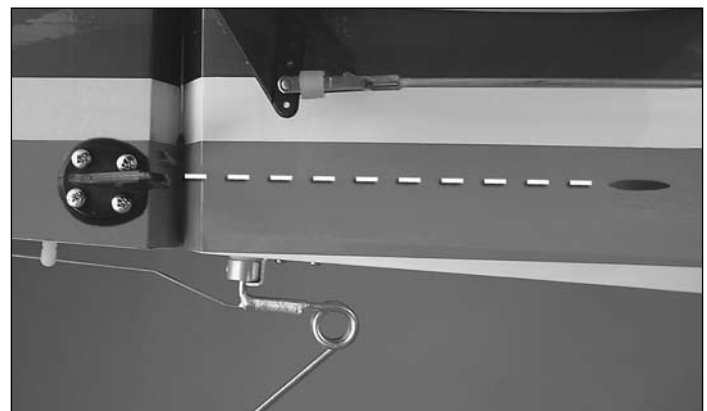

3. Locate the plywood mounting plates beneath the covering on both sides of the rudder. Place a control horn on each side of the rudder, positioning them as shown, aligning

them with the slots for the rudder cables. Mark the location for the screw holes. Drill through the marks you made with a 3/32" [2.4mm] drill bit. **Be sure you are drilling through the plate only!** Do not drill all the way through the rudder. Using a #4 x 5/8" [16mm] self-tapping screw, install and then remove a screw into each of the holes. Harden the holes with thin CA. Install the control horns with eight #4 x 5/8" [16mm] self-tapping screws.

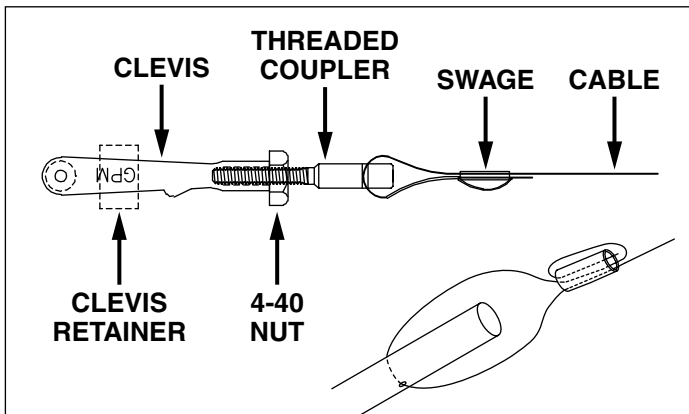
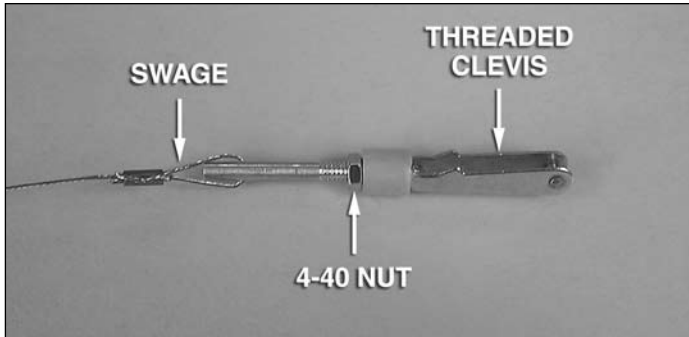

❑ 4. Cut the provided pull-pull cable into two equal lengths. Thread on a 4-40 nut and a silicone clevis retainer onto each of the four brass pull-pull couplers and then thread the couplers into four 4-40 metal clevises twelve complete turns. Feed only one end of each cable through the hole in a brass coupler 1-1/4" [32mm] and fold it back onto itself. Slide a swage onto the cable and over the short end, loop the short end around through the swage again and crimp the swage onto the cables using heavy-duty pliers. The other ends of the cables will be connected to the clevises after being installed into the fuselage.



❑ 5. Slide a 3" [76mm] piece of 1/16" [1.6mm] heat-shrink tubing onto each pull-pull cable. Use heat to shrink the tubing onto the cable. Slide the heat-shrink tubing down the cable so that the center of the tubing is 18" [457mm] from the **clevis pin**. Apply a drop of medium CA glue to both ends of each piece of tubing to secure it in place. The heat shrink tubing will prevent the metal cables from directly contacting each other where **they cross inside** the fuselage which could cause radio interference.

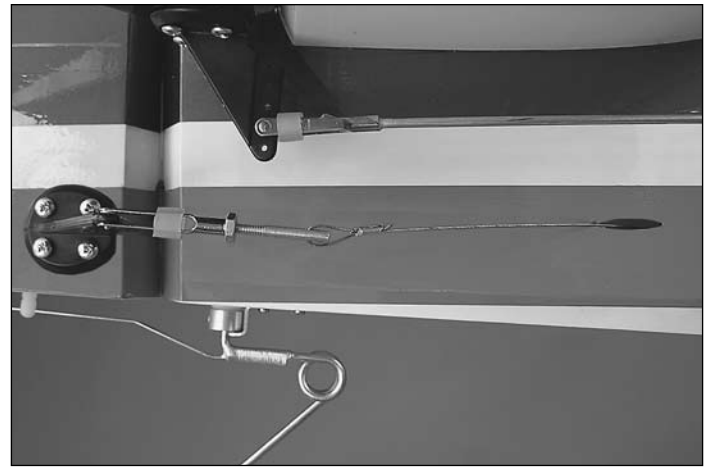

❑ 6. Feed the pull-pull cables through the slots in the fuselage. Be sure that the other ends make it through the fuselage to the rudder servos and do not interfere with the elevator servo leads. Turning the airplane up on its nose and feeding the cable ends into the fuse makes this task easier. Connect the clevises on the cables to the outer holes in the rudder control horns.

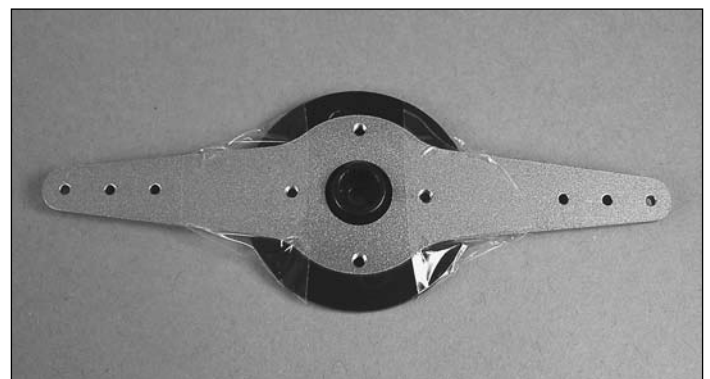
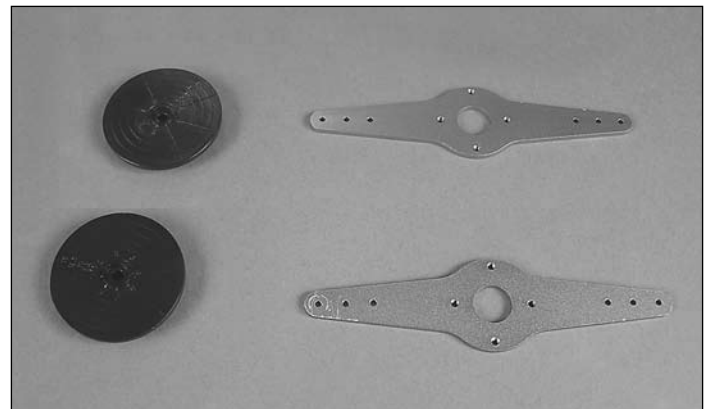

❑ 7. Two 3-7/8" [98mm] **double aluminum servo arm extensions** are included for the rudder pull-pull system. Locate the large servo wheels included with the rudder servos. (Different model servos may come with servo wheels that are larger or smaller than the ones shown in the picture. The actual size of the servo wheels being used is not critical.) Fit the aluminum servo extensions to the undersides of the servo wheels centered over the spline holes and tape them in place. Use a 1/16" [1.6mm] drill bit to drill through the four mounting holes in the servo extensions into the plastic servo wheels. Remove the servo wheels from the extensions and enlarge the holes with a 3/32" [2.4mm] drill bit.

USE THESE IMAGES FOR STEPS 8 AND 9

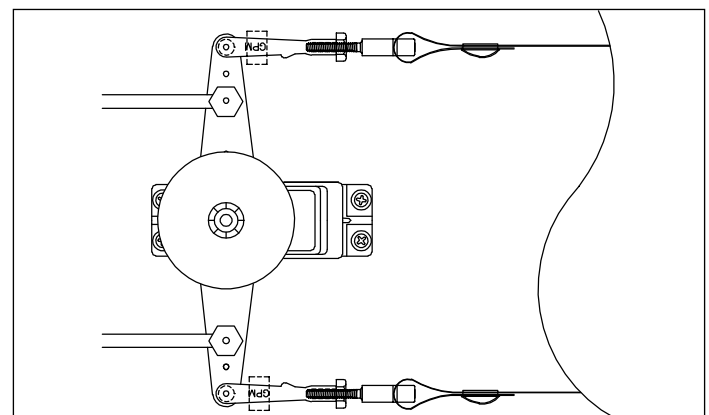
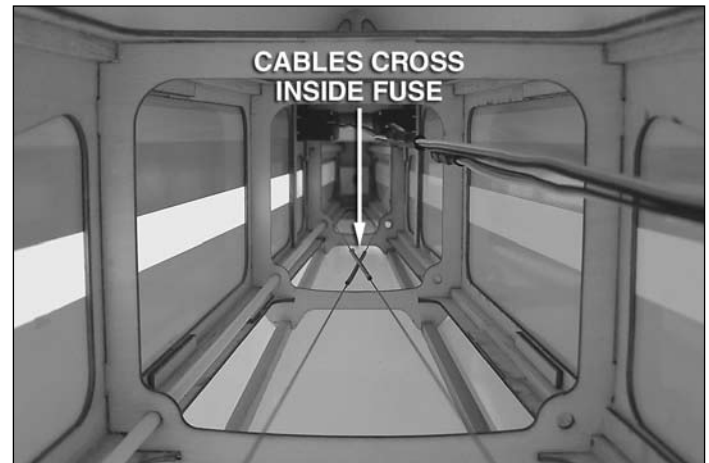
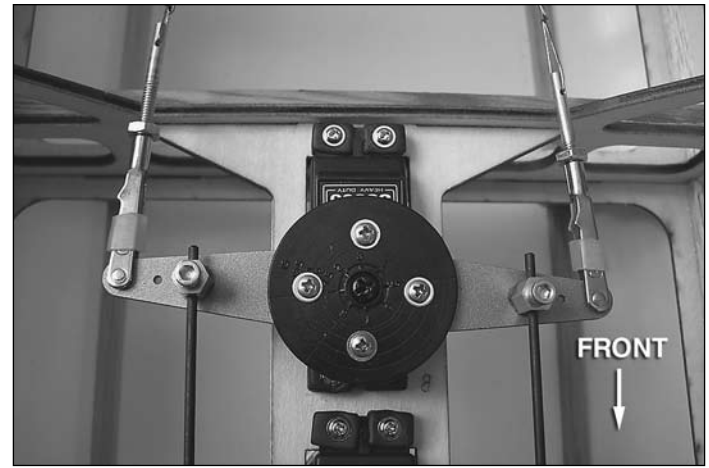
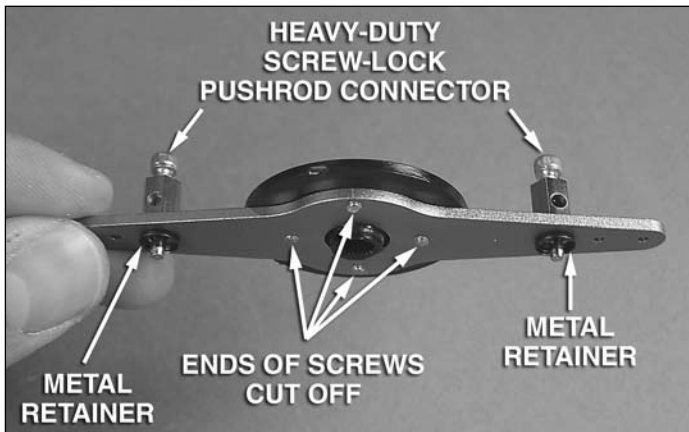

❑ 8. Using eight 2-56 x 3/8" [9.5mm] machine screws, eight #2 flat washers and **threadlocking compound**, attach the servo arm extensions to the servo wheels. With a cut-off wheel, cut off the ends of the screws that protrude from underneath the servo arm extensions.

❑ 9. Drill out the inner holes of both servo arm extensions using a 7/64" [2.8mm] bit. **Do not use any other size drill bit for this step.** Secure a heavy-duty screw-lock pushrod connector to each arm in the holes you just drilled out with a metal retainer. Loosely thread four 4-40 x 1/4" [6mm] SHCS into the screw-lock connectors.



❑ 10. With the servos centered using the radio and trims, align the servo arms perpendicular with the fuse centerline and parallel with each other and secure them to the rudder servos with the servo arm screws. Insert the two rudder servo joiner rods (included with the kit) through the screw-lock connectors as shown and tighten all the 4-40 SHCS.

❑ 11. Connect the other two clevis ends with the brass couplers installed onto the outer holes of the aft rudder servo extension. Check to be sure that the elevator servo wires are not entangled in the rudder pull-pull cables. Slide a swage onto the ends of the pull-pull cables inside the fuselage. Move the rudder to the neutral position and feed the ends of the cables through the holes in the brass couplers. The pull-pull cables will cross each other inside the fuselage. With both pull-pull cables having tension and the rudder in the neutral position, crimp the swages onto the cable ends to secure them as you did in step 4. You can fine-tune the tension on the lines by threading the clevises up or down on the couplers until satisfied. Then, tighten the 4-40 nuts against the clevises with threadlocking compound and slide the silicone clevis retainers over the clevises. Be sure that the rudder is in the neutral position when the cables are both tight and the rudder servos are perpendicular to the fuse.

Install the Rudder Servos in the Aft Position

RECOMMENDED INSTALLATION FOR GAS ENGINES

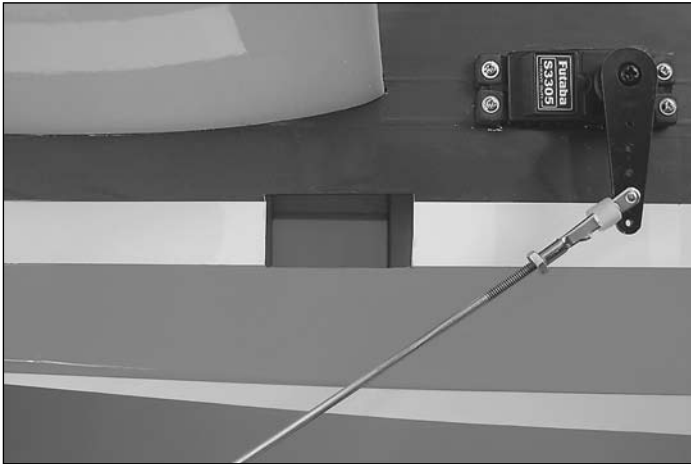

- ❑ 1. Trim the covering from the aft rudder servo bays leaving 1/8" [3mm] around the opening. Use a trim iron to seal down the covering around the edges of the servo bays. Temporarily unhooking one side of the elevator pushrods may be necessary.

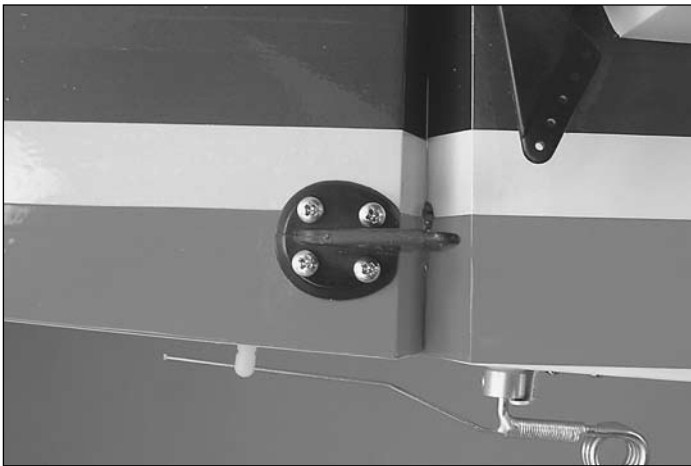

- ❑ 2. Locate the plywood mounting plates beneath the covering on both sides of the rudder. Place a heavy-duty nylon control horn on each side of the rudder, positioning them as shown. To avoid putting stress on the clevis pins, tilt the control horns at a slight downward angle (approximately 2° to 3°). Mark the location for the screw holes. Drill through the marks you made with a 3/32" [2.4mm] drill bit. **Be sure you are drilling through the plate only!** Do not drill all the way through the rudder. Using a #4 x 5/8" [16mm] self-tapping screw, install and then remove a screw into each of the holes. Harden the holes with thin CA. Install the control horns with eight #4 x 5/8" [16mm] self-tapping screws.



- ❑ 3. Attach a 36" [914mm] servo extension to each rudder servo. Secure the servo extensions with the included heat-shrink tubing. Feed the servo extensions through the fuselage and install the servos into the servo bays with the splines facing forward using the mounting hardware included with the servos. Be sure to harden the servo mounting screws with thin CA. Attach the servo arms pointing down as shown.

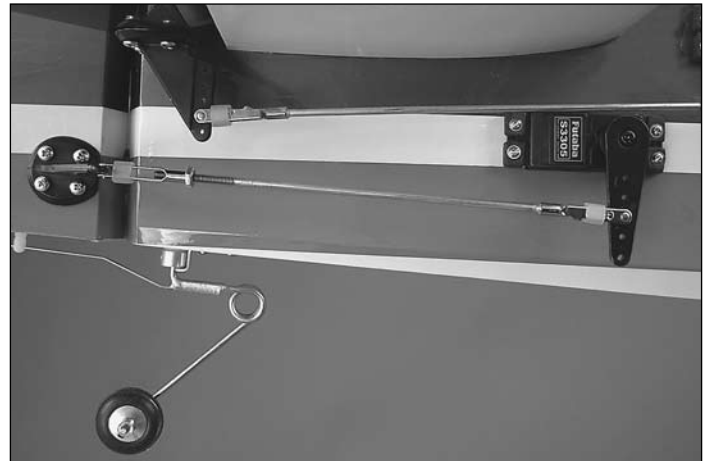

- ❑ 4. Assemble the rudder pushrods using two .095" x 12" [2.4mm x 305mm] pushrod wires threaded on one end, two 4-40 clevises, two 4-40 nuts, two solder clevises, and four silicone clevis retainers. Just as you did with the aileron and elevator pushrods, mark and cut the pushrods to length, solder the clevises to the pushrods, and attach the pushrods to the elevators, securing the clevises with silicone clevis retainers. Be sure to use threadlocking compound on the pushrod threads.

FINISH THE MODEL

Install the Radio System

Note: There are multiple locations to install the receiver and receiver pack depending on the power system being used and the ballast needed to balance the airplane at the recommended point. A **plywood auxiliary battery mount** is included and can be secured to the side of the motor mounting box. An aft radio tray is also provided that will accommodate both components. Read through the radio installation steps and choose the location that best suits your set-up.

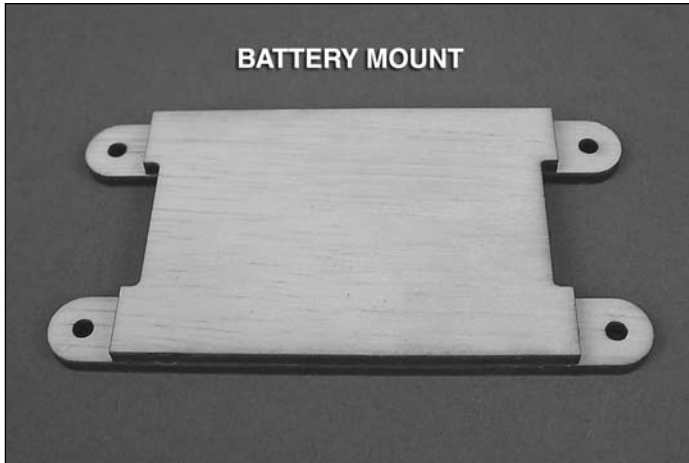

1. If weight is needed at the nose of the model for balancing purposes, locate the three **auxiliary battery mount** pieces (glow engine or brushless motor installation). Glue the two long pieces flush with the long sides of the large piece and centered left and right. Fuel proof the assembly.

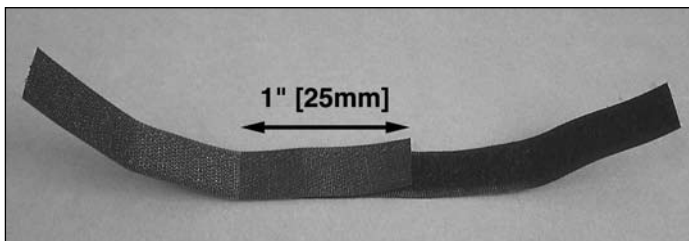

2. Cut a piece of foam rubber to fit your battery pack. Make a hook and loop strap to fit your pack by overlapping

the mating ends of the included hook and loop material by approximately 1" [25mm]. The total length of the strap you make will be determined by the size of your pack. Place the foam rubber onto the battery mount and use the hook and loop strap to secure the battery to the mount.

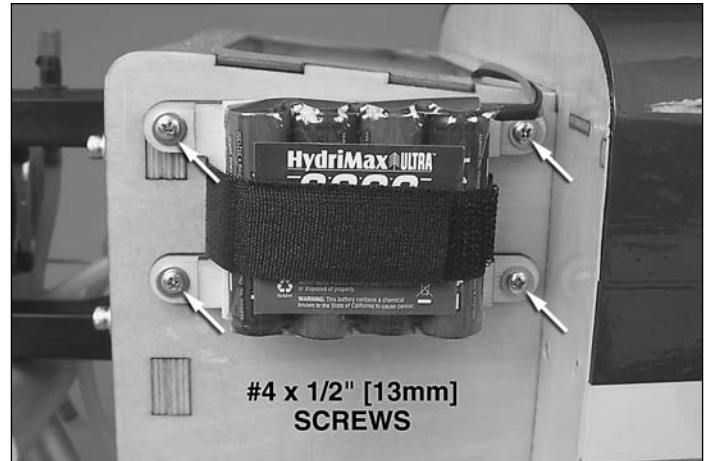

3. Place the mount onto the motor mounting box side and mark the locations for the four mounting holes. Drill 3/32" [2.4mm] holes at your marks. Thread a #4 x 1/2" [13mm] screw into each hole and back it out. Apply a couple drops of thin CA to each hole to harden the wood. Screw the mount to the firewall using four #4 x 1/2" [13mm] screws and four #4 flat washers. Be sure that the battery pack is properly secured to the battery mount. The mount can also be installed so the hook and loop strap is oriented vertically.

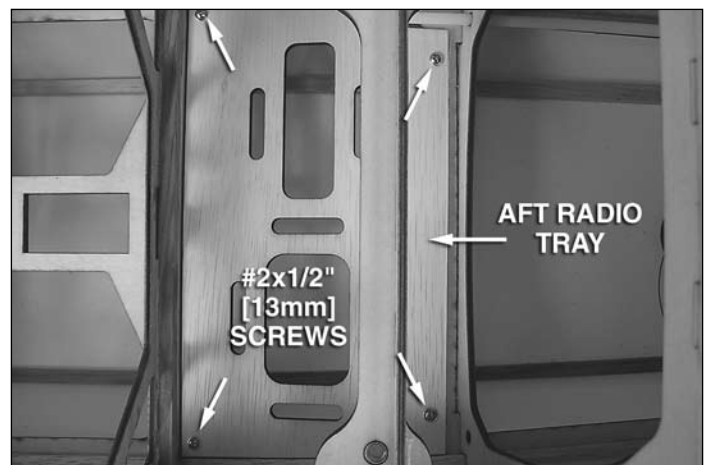

4. If you have installed a gas engine, you will need to install the **aft radio tray**. Position the tray in place as shown and use a 1/16" [1.6mm] drill bit to drill four mounting holes in the locations shown. Thread a #2 x 1/2" [13mm] self-tapping screw into each hole and remove it. Apply a couple drops of thin CA to each hole to harden the wood. Secure the tray with four #2 x 1/2" [13mm] self-tapping screws and four #2 flat washers.

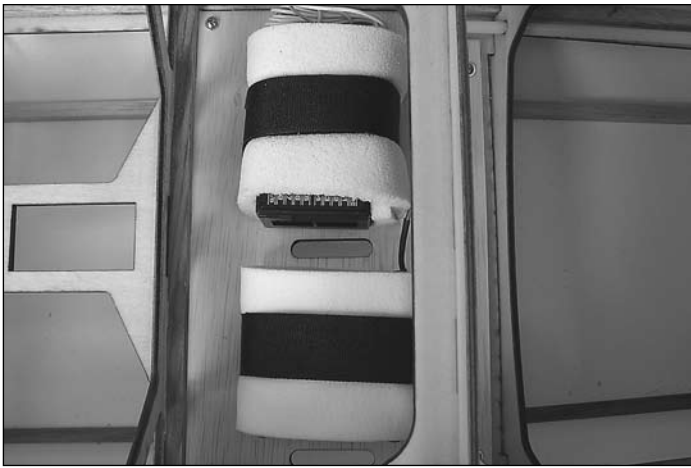

❑ 5. Make straps from the included hook and loop material for your receiver and receiver pack. Wrap the components in 1/4" [6mm] foam rubber and strap them to the aft radio tray.

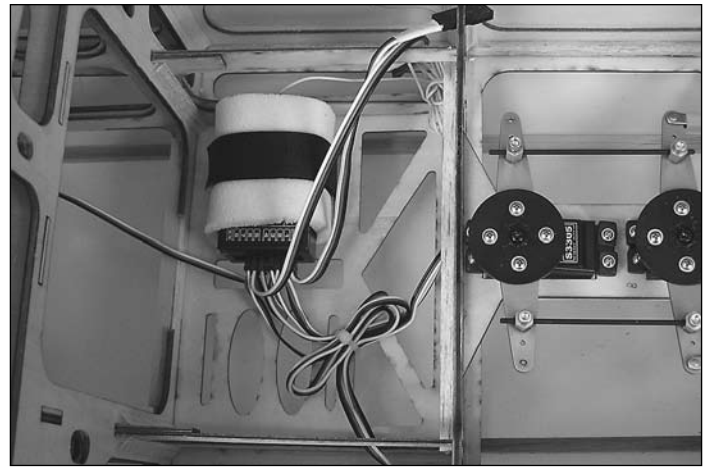

❑ 7. With the radio component locations determined, connect the servos to the receiver. If you do not plan to use a programmable radio that is capable of mixing, a Y-harness will be required for the aileron and rudder servos. The elevator servos will require a reversing Y-harness (a reversing Y-harness will reverse the direction of one of the servos). Cut small pieces from a rubber band to make straps that will hold the servo leads away from the pull-pull cables.

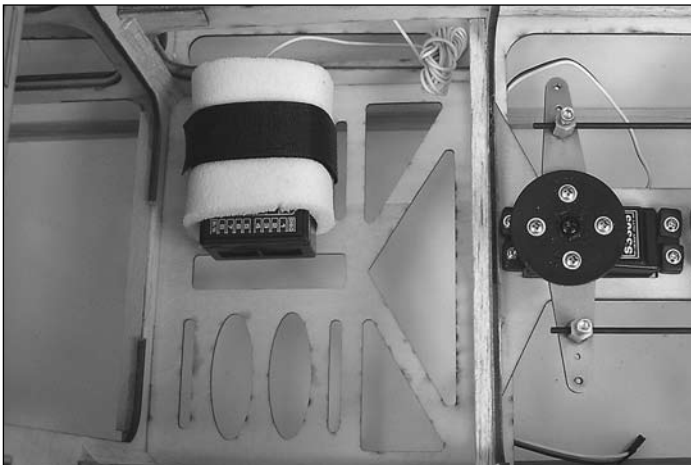

❑ 6. If you have installed a glow engine, the receiver pack can be mounted either on the auxiliary battery mount (shown in step 3) or on the forward radio tray. The O.S. 1.60 FX engine requires additional weight at the nose of the airplane, so only the receiver is installed on the forward radio tray in our set-up shown above.



❑ 8. Feed the receiver antenna around the rudder servos (if applicable) and into the receiver antenna tube. Use a piece of tape around the tube and antenna to prevent it from falling out. Silicone sealant can also be used.

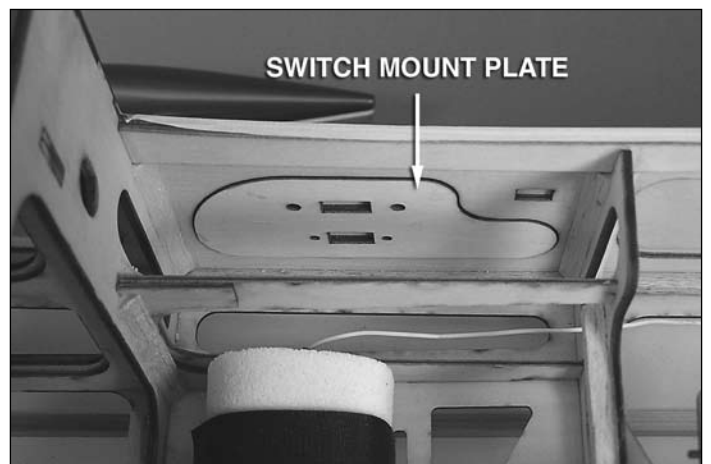



❑ 9. Pre-cut switch mount plates are included to fit a Hobbico brand heavy-duty switch harness, Futaba brand heavy-duty switch harness, Ernst charge jack receptacles, and a blank plate to fit any other type of switch. Glue the plate that matches your hardware in the location shown. The plate can be installed on either side of the fuse. A larger plate is also included that fits further aft on the side of the fuselage for a gas engine installation. Use a covering iron to bond the covering to the plate. Install your receiver switch and charge jack onto the plate.

EXPERT TIP
EXPERT TIP

For added strength, after the cowl mounting blocks have been securely epoxied in place, drill 1/8" [3.2mm] holes through the center of each block and through the firewall. Insert an appropriate length of 1/8" [3.2mm] dowel (not included) into the holes and into the firewall. Glue the dowels in place with epoxy and sand the dowels flush with the face of the blocks. This modification is especially important when using a high vibration engine.

❑ 2. Fuel-proof the cowl mounting blocks with epoxy.

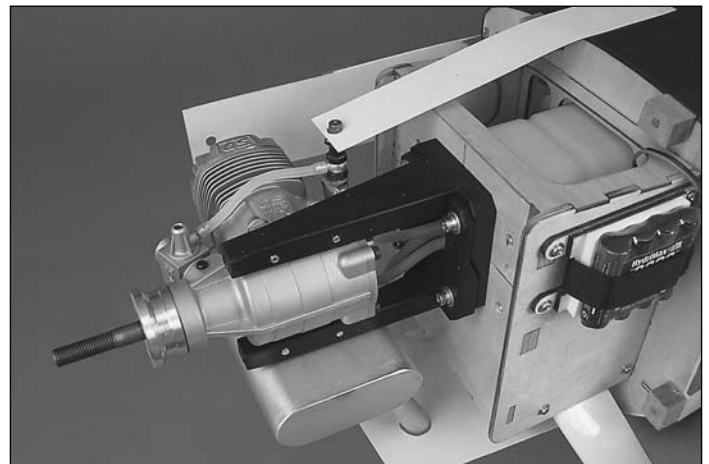

❑ 3. In order to fit the **cowl** in place, the muffler will need to be removed from the engine. Before you unbolt it, make a paper template for the location of the exhaust outlets and tape it to the underside of the fuselage. Also make templates for access to the glow plug, needle valve, etc.

Install the Cowl

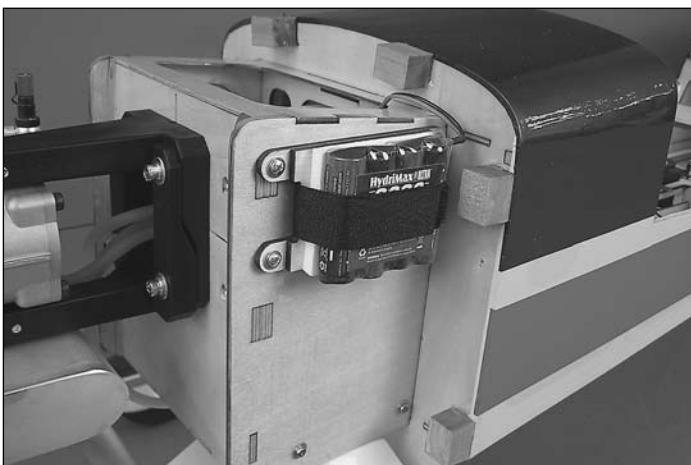

❑ 1. Position the six **cowl mounting blocks** onto the firewall in the positions shown and trace around them onto the firewall. The outside of the blocks should be flush with the fuselage sides. Remove the epoxy from the areas on the firewall beneath the cowl mounting block locations with 220 grit sandpaper. When satisfied, use 30-minute epoxy to glue the cowl blocks in position. A small dot of medium or thick CA glue will hold the blocks in place while the epoxy cures.

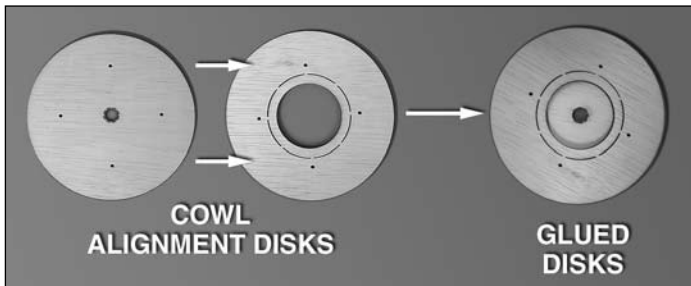
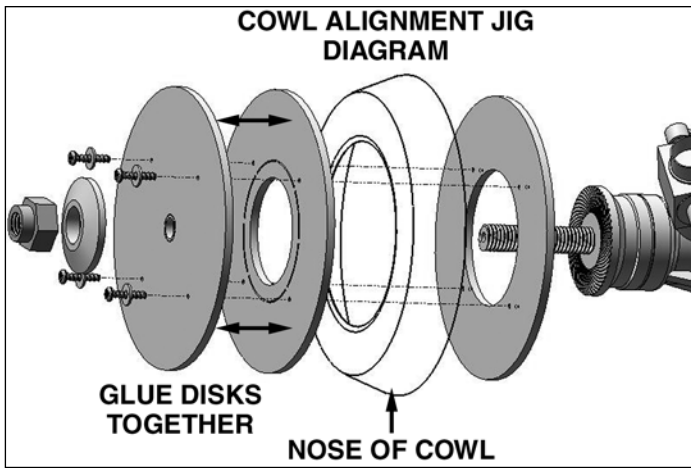

❑ 4. Locate the three **cowl alignment disks**. Cut the perforations in the two disks to match the size of your engine crankshaft (or prop bolt) and drive washer. Carefully glue the two disks that have perforations together, being sure to align the four screw holes. The cowl alignment jig will allow easy positioning of the cowl onto the fuse without needing tape or a second set of hands.

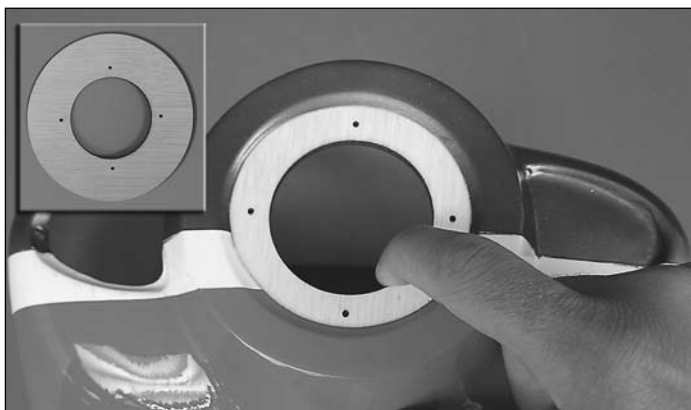

❑ 5. The cowl alignment disk with the large hole in the center fits on the **inside** of the cowl as shown. Use four #4

x 5/8" [16mm] self-tapping screws and four #4 flat washers to screw the assembly you made in step 4 to the disk that is inside of the cowl. The front flange of the cowl should be sandwiched between the rear disk on the inside of the cowl and the two disks in front. Carefully center the front disks over the front of the cowl and tighten the screws.

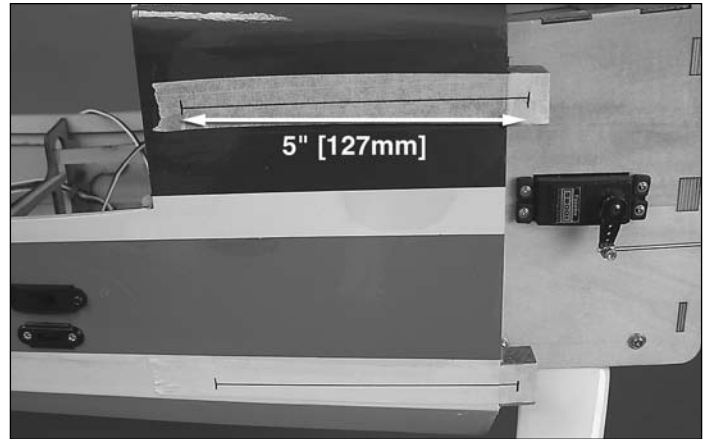

❑ 6. Apply strips of masking tape approximately 6" [152mm] long from the cowl mounting blocks back along the fuselage as shown (make the tape parallel with the length of the fuse). Measure from the center of each cowl mounting block 5" [127mm] back and draw a straight line down the tape between your marks.



❑ 7. With the cowl alignment jig installed on the front of the cowl, slide the cowl onto the engine crankshaft and use the prop washer and nut to hold it in place. Align the colors on

the cowl with the covering on the fuse and gently tighten the nut. Measure 5" [127mm] along the lines on the tape and mark the locations of the center of each mounting block onto the cowl. Also, use the templates to mark the locations of the exhaust outlets, needle valve and glow plug access, etc. onto the cowl.

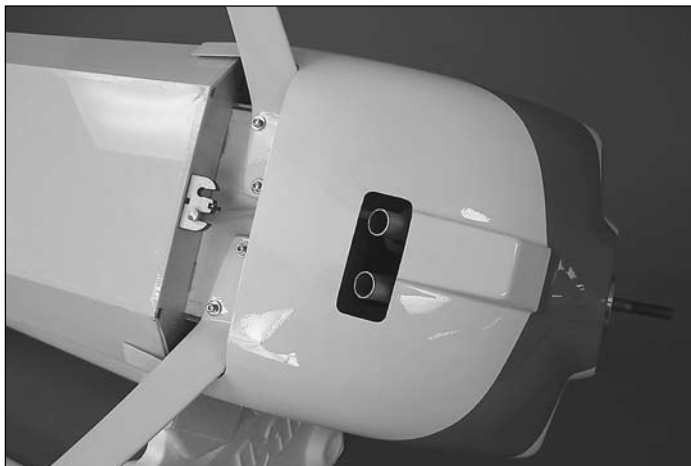
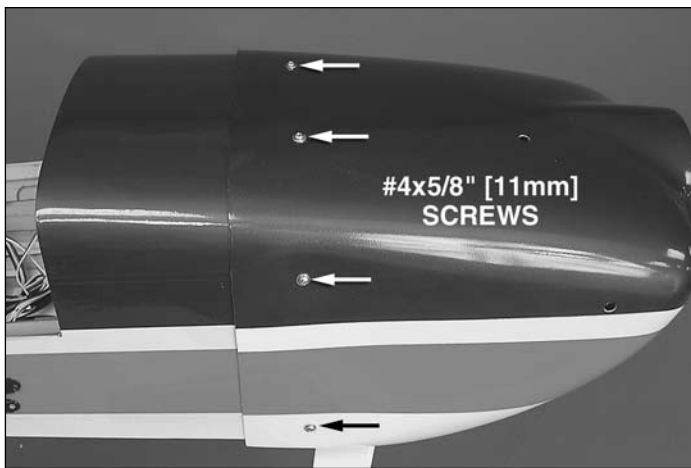

❑ 8. Drill 3/32" [2.4mm] holes through the cowl and into the cowl mounting blocks at the marks you made. Remove the cowl from the fuse and the alignment jig from the front of the cowl and enlarge the holes in the cowl using a 7/64" [2.8mm] bit. This will prevent the cowl from splitting when the cowl mounting screws are installed. Thread a #4 x 5/8" [16mm] screw into each mounting block and remove it. Apply a couple drops of thin CA to each hole to harden the wood. Make the necessary cutouts in the cowl (cooling hole and exhaust exit, glow plug access, needle valve access, etc.) using a rotary tool. Bolt the muffler to the engine and install the cowl onto the fuse using six #4 x 5/8" [16mm] self-tapping screws and six #4 flat washers (use the four #4 x 5/8" [16mm] screws and washers from the cowl alignment jig).

Install the Canopy Hatch



❑ 1. Glue the **canopy hatch dowel** into the front of the **canopy hatch** so half of it protrudes beyond the front of the hatch.

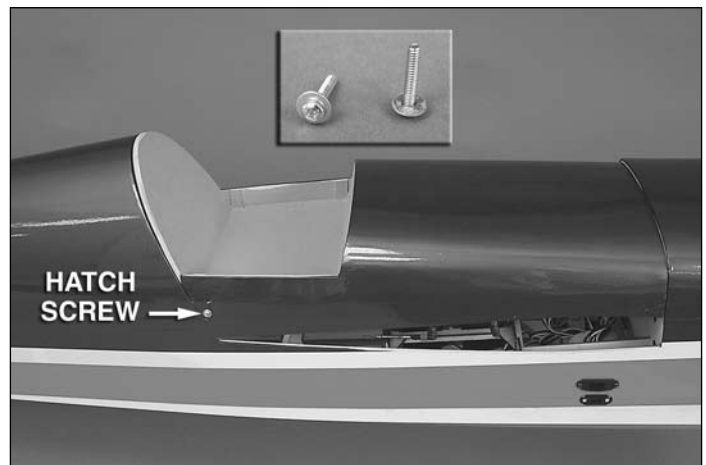

❑ 2. Glue a #4 flat washer to each of the two 4-40 x 3/4" [19mm] machine screws used to mount the canopy hatch to the fuselage. Gluing the washers in place will help prevent them from becoming lost at the flying field. Put the canopy hatch in place and use the screws to test fit it to the fuse. When the wing is also installed, it will hold the front of the canopy hatch flush with the top fuse sheeting. This can be checked now or at the end of the build.



❑ 3. If you plan to install a pilot and the instrument panel decal, do so before gluing the canopy in place. The picture

shows pilot GPMQ9012 (not included). The height of the pilot will need to be shortened by approximately 1/4" [6mm] to fit beneath the canopy. We cut a piece of plywood to replace the base of the pilot that was cut off. The plywood base can be glued inside the pilot figure with medium or thick CA, or a mixture of microballoons and epoxy. Glue the pilot into place or use double-sided foam servo tape (not included) with a couple of screws through the underside.

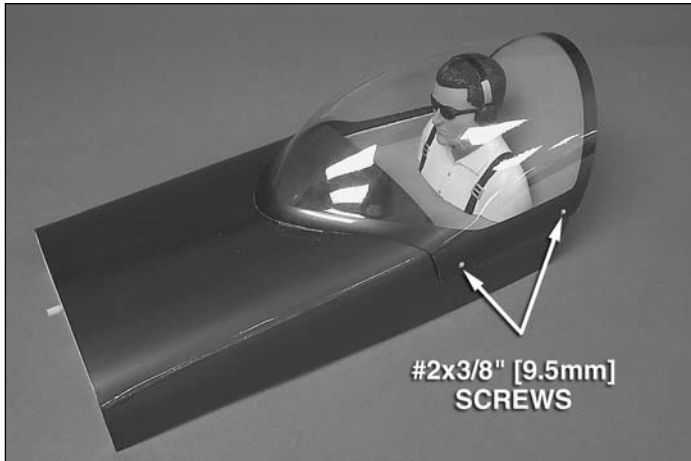

❑ 4. Align the canopy onto the canopy hatch. Drill 1/16" [1.6mm] holes at each of the four plywood canopy mounting plates (these can be seen on the inside of the cockpit compartment). Thread a #2 x 3/8" [9.5mm] self-tapping screw into each hole and back it out. Apply a couple drops of thin CA to each hole to harden the wood. Use canopy glue such as Pacer Formula 560 to glue the canopy to the canopy hatch. Finish the canopy installation by securing it to the hatch using four #2 x 3/8" [9.5mm] self-tapping screws and four #2 flat washers.

Install the Propeller and Spinner

SPINNER INSTRUCTIONS FOR O.S. MAX 1.60 FX



❑ 1. Slide the **spinner backplate** onto the crankshaft. Ream the propeller as necessary to fit the engine and push it onto the crankshaft (don't forget to balance your prop!). Install the prop washer and mating jam nut onto the crankshaft and properly tighten the nut. If you are installing a Fuji-Imvac BT-43 EI-2 engine, use the included brass spinner backplate adapter.



❑ 2. Tighten the **spinner adapter** against the prop nut (not used with a gas engine).



3. Secure the **spinner** to the adapter with the 5x54mm spinner screw. If the screw is too long, use a cutoff tool such as a Dremel rotary tool to shorten the screw. Thread the included 5mm nut onto the spinner screw before cutting. When the nut is removed, it will straighten the threads on the screw that may have been deformed from the cutting process. **Note:** The process for attaching the spinner to a Fuji-Imvac BT-43 EI-2 engine is the same as the 1.60 FX. However, you will use the spinner bolt included with the engine instead of the spinner adapter shown above. There is a longer 70mm [2-3/4"] spinner screw provided for use with gas engines.

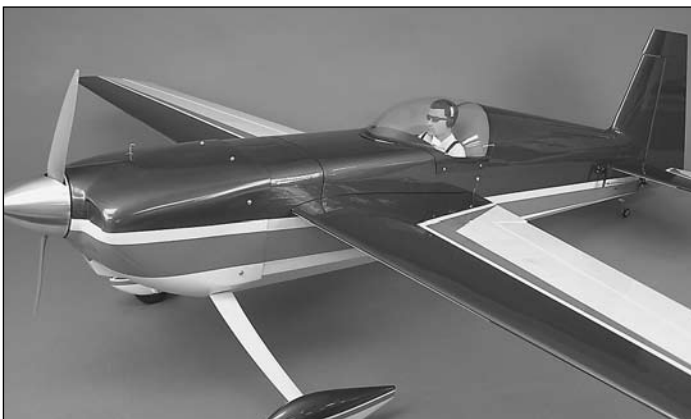

4. This completes the building instructions for the Edge 540 1.60 ARF!

Apply the Decals

- Use scissors or a sharp hobby knife to cut the decals from the sheet.
- Be certain the model is clean and free from oily fingerprints and dust. Prepare a dishpan or small bucket with a mixture of liquid dish soap and warm water—about one teaspoon of soap per gallon of water. Submerge the decal in the soap and water and peel off the paper backing. **Note:** Even though the decals have a “sticky-back” and are not the water transfer type, submersing them in soap and water allows accurate positioning and reduces air bubbles underneath.
- Position decal on the model where desired. Holding the decal down, use a paper towel to wipe most of the water away.
- Use a piece of soft balsa or something similar to squeegee remaining water from under the decal. Apply the rest of the decals the same way.

GET THE MODEL READY TO FLY

Install and Connect the Motor Battery

Before you can power the radio system and set up the controls, the motor batteries will need to be charged.

IMPORTANT: If using multiple battery packs that are connected with an adapter, never charge the batteries together through the adapter. Always charge each battery pack separately. Charge the batteries, then read the following precautions on how to connect multiple packs for flying the model.

BATTERY PRECAUTIONS

There are two ways to connect multiple battery packs: In **Series** and in **Parallel**.

These are two 3200mAh batteries (one 11.1V and the other 7.4V). When joined in **SERIES**, the result will be a 18.5V, 3200 mAh battery.

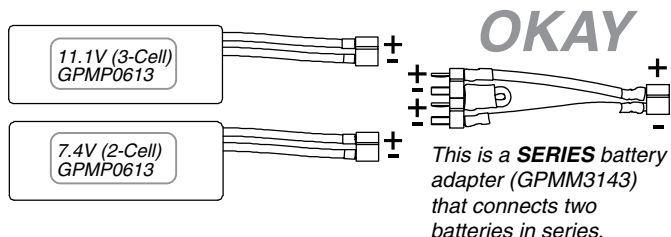

It's okay to connect batteries with different voltages in series to achieve the new, desired voltage.

1. Connecting batteries in “**Series**” means to connect the (+)'s to the (-)'s and the (-)'s to the (+)'s. This combines the voltages of the batteries, but the capacity remains the same.

These two 1500mAh batteries (both 11.1V) are being joined in **PARALLEL**. The result will be one 11.1V, 3000mAh battery.

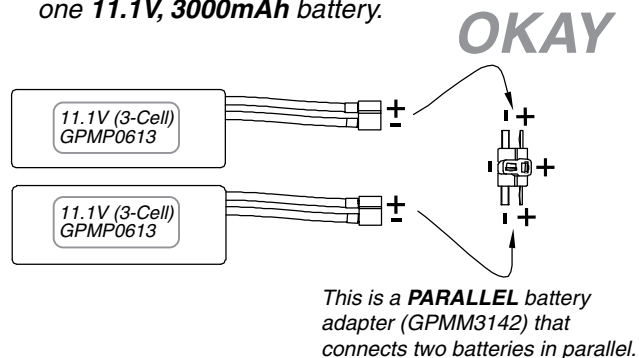

2. Connecting batteries in “**Parallel**” means to connect the (+)'s to the (+)'s and the (-)'s to the (-)'s. This combines the capacities of the batteries, but the voltage remains the same.

NO!!!

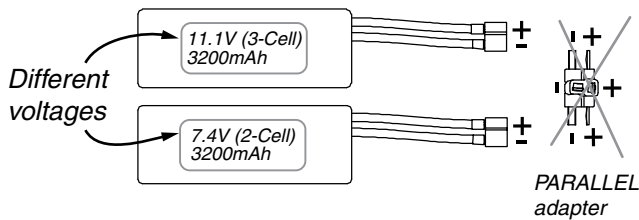

NEVER connect battery packs with different voltages in parallel! Only combine them in series. Otherwise, the batteries with lower voltage will try to “equalize” with the batteries that have a higher voltage. Current will flow from the higher voltage battery into the lower one, essentially “charging” the lower voltage battery pack. This situation will likely cause heat and possibly a fire.

NO!!!

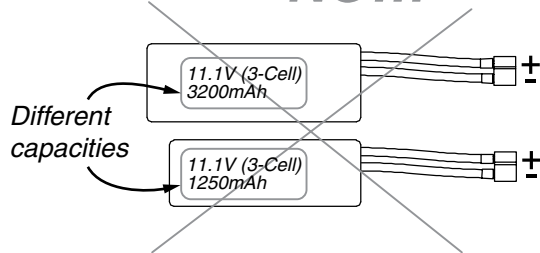

NEVER connect battery packs with different capacities in series or in parallel.

LITHIUM BATTERY HANDLING AND USAGE

WARNING!! Read the entire instruction sheet included with the battery. Failure to follow all instructions could cause permanent damage to the battery and its surroundings, and cause bodily harm!

- ONLY use a LiPo approved charger. NEVER use a NiCd/NiMH peak charger!
- NEVER charge in excess of 4.20V per cell.
- ONLY charge through the “charge” lead. NEVER charge through the “discharge” lead.
- NEVER charge at currents greater than 1C.
- ALWAYS set charger’s output volts to match battery volts.
- ALWAYS charge in a fireproof location.
- NEVER trickle charge.
- NEVER allow battery temperature to exceed 150°F (65°C).
- NEVER disassemble or modify pack wiring in any way or puncture cells.
- NEVER discharge below 2.5V per cell.
- NEVER place on combustible materials or leave unattended during charge or discharge.
- ALWAYS KEEP OUT OF REACH OF CHILDREN.

Check the Control Directions

1. Turn on the transmitter and receiver and center the trims. If necessary, remove the servo arms from the servos and reposition them so they are centered. Reinstall the screws that hold on the servo arms.
2. With the transmitter and receiver still on, check all the control surfaces to see if they are centered. If necessary, adjust the clevises on the pushrods to center the control surfaces.

4-CHANNEL RADIO SETUP (STANDARD MODE 2)

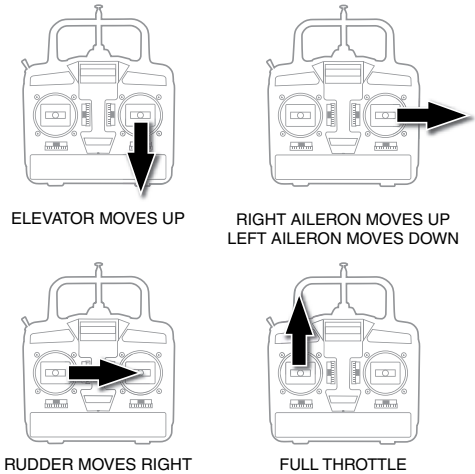

3. Make certain that the control surfaces and the carburetor respond in the correct direction as shown in the diagram. If any of the controls respond in the wrong direction, use the servo reversing in the transmitter to reverse the servos connected to those controls. Be certain the control surfaces have remained centered. Adjust if necessary.

Set the Control Throws

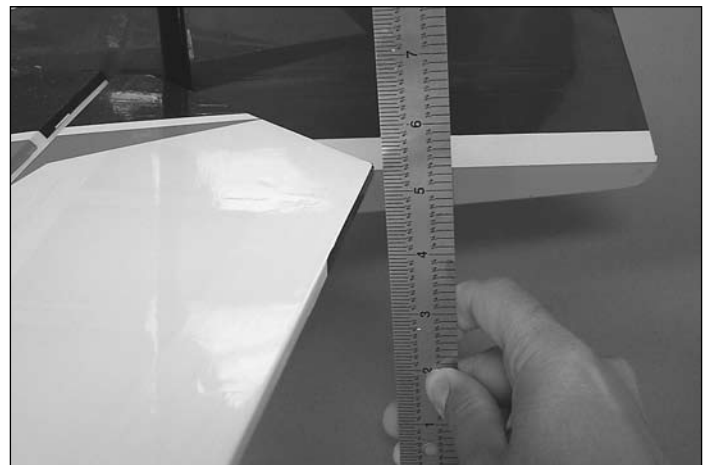

Use a ruler to accurately measure and set the control throw of each control surface as indicated in the chart that follows. If your radio does not have dual rates, we recommend setting the throws at the **low** rate setting for your first few flights.

These are the recommended control surface throws:

HIGH RATE

ELEVATOR:	2" [51mm], 22° up 2" [51mm], 22° down
RUDDER:	4-1/2" [114mm], 27° left 4-1/2" [114mm], 27° right
AILERONS:	3/4" [19mm], 12° up 3/4" [19mm], 12° down

LOW RATE

ELEVATOR:	1-1/2" [38mm], 17° up 1-1/2" [38mm], 17° down
RUDDER:	3" [76mm], 18° left 3" [76mm], 18° right
AILERONS:	1/2" [13mm], 8° up 1/2" [13mm], 8° down

3D RATE

ELEVATOR:	2-3/4" [70mm], 32° up 2-3/4" [70mm], 32° down
RUDDER:	5-1/2" [140mm], 34° left 5-1/2" [140mm], 34° right
AILERONS:	1-7/8" [48mm], 32° up 1-7/8" [48mm], 32° down

NOTE: The throws are measured at the **widest** part of the control surfaces.

IMPORTANT: The Edge 540 1.60 ARF has been **extensively** flown and tested to arrive at the throws at which it flies best. Flying your model at these throws will provide you with the greatest chance for successful first flights. If, after you have become accustomed to the way the Edge 540 flies, you would like to change the throws to suit your taste, that is fine. However, too much control throw could make the model difficult to control, so remember, "more is not always better."

Balance the Model (C.G.)

More than any other factor, the **C.G.** (balance point) can have the **greatest** effect on how a model flies, and may determine whether or not your first flight will be successful. If you value this model and wish to enjoy it for many flights, **DO NOT OVERLOOK THIS IMPORTANT PROCEDURE.** A model that is not properly balanced will be unstable and possibly unflyable.

At this stage the model should be in ready-to-fly condition with all of the systems in place including the engine, landing gear, covering and paint, and the radio system.

❑ 1. Use a felt-tip pen or 1/8" [3mm]-wide tape to accurately mark the C.G. on the top of the wing on both sides of the fuselage. The C.G. is located 4-5/16" [110mm] back from the leading edge of the wing.

This is where your model should balance for the first flights. Later, you may wish to experiment by shifting the C.G. up to 1/2" [13mm] forward or 1/2" [13mm] back to change the flying characteristics. Moving the C.G. forward may improve the smoothness and stability, but the model may then require more speed for takeoff and make it more difficult to slow for landing. Moving the C.G. aft makes the model more maneuverable, but could also cause it to become too difficult to control. In any case, **start at the recommended balance point** and do not at any time balance the model outside the specified range.

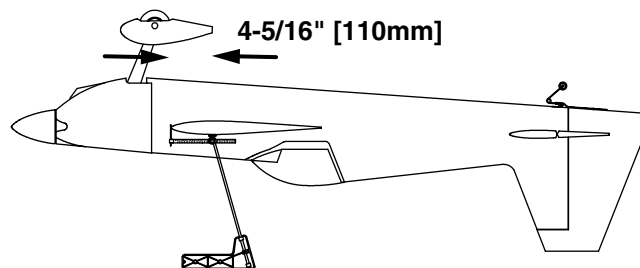

❑ 2. With the wing attached to the fuselage, all parts of the model installed (ready to fly) and an empty fuel tank, place the model upside-down on a Great Planes CG Machine, or lift it at the balance point you marked. If you are using a brushless motor, be sure to balance the airplane with the battery pack installed.

❑ 3. If the tail drops, the model is "tail heavy" and the receiver battery pack and/or receiver must be shifted forward or weight must be added to the nose to balance (also see rudder servo installation section). If the nose drops, the model is "nose heavy" and the receiver battery pack and/or receiver must be shifted aft or weight must be added to the tail to balance (also see rudder servo installation section). If possible, relocate the battery pack and receiver to minimize or eliminate any additional ballast required. If additional weight is required, use Great Planes (GPMQ4485) "stick on" lead. A good place to add stick-on nose weight is to the motor mounting box (don't attach weight to the cowl—it is not intended to support weight). Begin by placing incrementally increasing amounts of weight on the bottom of the fuse over the firewall until the model balances. Once you have determined the amount of weight required, it can be permanently attached. If required, tail weight may be added by cutting open the bottom of the fuse and gluing it permanently inside.

Note: Do not rely upon the adhesive on the back of the lead weight to permanently hold it in place. Over time, fuel and exhaust residue may soften the adhesive and cause the weight to fall off. Use #2 sheet metal screws, RTV silicone, or epoxy to permanently hold the weight in place.

❑ 4. **IMPORTANT:** If you found it necessary to add any weight, recheck the C.G. after the weight has been installed.

Balance the Model Laterally

- ❑ 1. With the wing level, have an assistant help you lift the model by the engine propeller shaft and the bottom of the fuse under the TE of the fin. Do this several times.
- ❑ 2. If one wing always drops when you lift the model, it means that side is heavy. Balance the airplane by adding weight to the other wing tip. **An airplane that has been laterally balanced will track better in loops and other maneuvers.**

PREFLIGHT

Identify Your Model

No matter if you fly at an AMA sanctioned R/C club site or if you fly somewhere on your own, you should always have your name, address, telephone number and AMA number on or inside your model. It is **required** at all AMA R/C club flying sites and AMA sanctioned flying events. Fill out the identification tag on page 55 (or on the decal sheet) and place it on or inside your model.

Charge the Batteries

Follow the battery charging instructions that came with your radio control system to charge the batteries. You should always charge your transmitter and receiver batteries the night before you go flying, and at other times as recommended by the radio manufacturer.

CAUTION: Unless the instructions that came with your radio system state differently, the **initial** charge on new transmitter and receiver batteries should be done for 15 hours **using the slow-charger that came with the radio system**. This will “condition” the batteries so that the next charge may be done using the fast-charger of your choice. If the initial charge is done with a fast-charger the batteries may not reach their full capacity and you may be flying with batteries that are only partially charged.

Balance Propellers

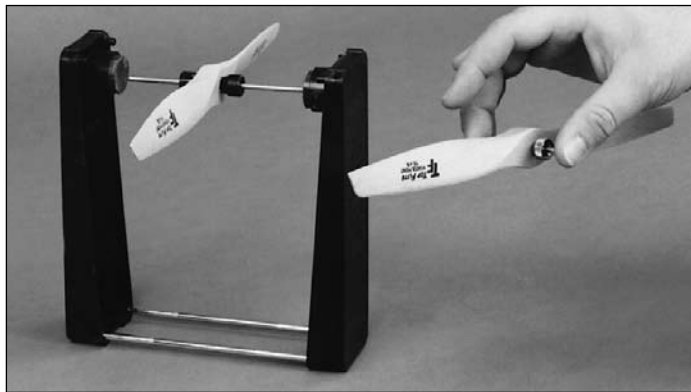

Carefully balance your propeller and spare propellers before you fly. An unbalanced prop can be the single most significant cause of vibration that can damage your model. Not only will engine mounting screws and bolts loosen, possibly with disastrous effect, but vibration may also damage your radio receiver and battery. Vibration can also cause your fuel to foam, which will, in turn, cause your engine to run hot or quit. We use a Top Flite Precision Magnetic Prop Balancer™ (TOPQ5700) in the workshop and keep a Great Planes Fingertip Prop Balancer (GPMQ5000) in our flight box.

Ground Check

If the engine is new, follow the engine manufacturer's instructions to break-in the engine. After break-in, confirm that the engine idles reliably, transitions smoothly and rapidly to full power and maintains full power—indefinitely. After you run the engine on the model, inspect the model closely to make sure all screws remained tight, the hinges are secure, the prop is secure and all pushrods and connectors are secure.

Range Check

Ground check the operational range of your radio before the first flight of the day. With the transmitter antenna collapsed and the receiver and transmitter on, you should be able to walk at least 100 feet away from the model and still have control. Have an assistant stand by your model and, while you work the controls, tell you what the control surfaces are doing. Repeat this test **with the engine running** at various speeds with an assistant holding the model, using hand signals to show you what is happening. If the control surfaces do not respond correctly, **do not fly!** Find and correct the problem first. Look for loose servo connections or broken wires, corroded wires on old servo connectors, poor solder joints in your battery pack or a defective cell, or a damaged receiver crystal from a previous crash.

ENGINE SAFETY PRECAUTIONS

Failure to follow these safety precautions may result in severe injury to yourself and others.

- Keep all engine fuel in a safe place, away from high heat, sparks or flames, as fuel is very flammable. Do not smoke near the engine or fuel; and remember that engine exhaust gives off a great deal of deadly carbon monoxide. Therefore **do not run the engine in a closed room or garage.**
- Get help from an experienced pilot when learning to operate engines.
- Use safety glasses when starting or running engines.
- Do not run the engine in an area of loose gravel or sand; the propeller may throw such material in your face or eyes.
- Keep your face and body as well as all spectators away from the plane of rotation of the propeller as you start and run the engine.
- Keep these items away from the prop: loose clothing, shirt sleeves, ties, scarves, long hair or loose objects such as pencils or screwdrivers that may fall out of shirt or jacket pockets into the prop.
- Use a “chicken stick” or electric starter to start the engine. Do not use your fingers to flip the propeller. Make certain the glow plug clip or connector is secure so that it will not pop off or otherwise get into the running propeller.
- Make all engine adjustments from behind the rotating propeller.
- The engine gets hot! Do not touch it during or right after operation. Make sure fuel lines are in good condition so fuel will not leak onto a hot engine, causing a fire.
- To stop a glow engine, cut off the fuel supply by closing off the fuel line or following the engine manufacturer's recommendations. Do not use hands, fingers or any other body part to try to stop the engine. To stop a gasoline powered engine an on/off switch should be connected to the engine coil. Do not throw anything into the propeller of a running engine.

AMA SAFETY CODE (EXCERPTS)

Read and abide by the following excerpts from the Academy of Model Aeronautics Safety Code. For the complete Safety Code refer to *Model Aviation* magazine, the AMA web site or the Code that came with your AMA license.

General

- 1) I will not fly my model aircraft in sanctioned events, air shows, or model flying demonstrations until it has been proven to be airworthy by having been previously, successfully flight tested.
- 2) I will not fly my model aircraft higher than approximately 400 feet within 3 miles of an airport without notifying the airport operator. I will give right-of-way and avoid flying in the proximity of full-scale aircraft. Where necessary, an observer shall be utilized to supervise flying to avoid having models fly in the proximity of full-scale aircraft.
- 3) Where established, I will abide by the safety rules for the flying site I use, and I will not willfully and deliberately fly my models in a careless, reckless and/or dangerous manner.
- 5) I will not fly my model unless it is identified with my name and address or AMA number, on or in the model. Note: This does not apply to models while being flown indoors.
- 7) I will not operate models with pyrotechnics (any device that explodes, burns, or propels a projectile of any kind).

Radio Control

- 1) I will have completed a successful radio equipment ground check before the first flight of a new or repaired model.
- 2) I will not fly my model aircraft in the presence of spectators until I become a qualified flier, unless assisted by an experienced helper.
- 3) At all flying sites a straight or curved line(s) must be established in front of which all flying takes place with the other side for spectators. Only personnel involved with flying the aircraft are allowed at or in the front of the flight line. Intentional flying behind the flight line is prohibited.
- 4) I will operate my model using only radio control frequencies currently allowed by the Federal Communications Commission.
- 5) **I will not knowingly operate my model within three miles of any pre-existing flying site except in accordance with the frequency sharing agreement listed [in the complete AMA Safety Code].**
- 9) Under no circumstances may a pilot or other person touch a powered model in flight; **nor should any part of the model other than the landing gear, intentionally touch the ground, except while landing.**

IMAA SAFETY CODE (EXCERPTS)

Since the Edge 540 1.60 ARF qualifies as a “giant scale” model and is therefore eligible to fly in IMAA events, we’ve printed excerpts from the IMAA Safety Code.

What is Giant-Scale? The concept of large or giant-scale is generally considered to apply to radio controlled model aircraft with minimum wingspans of 80 inches for monoplanes and 60 inches for multi-wing aircraft. Quarter-scale or larger replicas of person-carrying aircraft with proper documentation (minimum 3-view drawing) which do not fit the size requirements will also be permitted.

Section 1.0: Safety Standard

- 1.1) Adherence to Code: The purpose of this Safety Code is to provide a structure whereby all participants, including spectators, will be aware of the inherent dangers in the operation of radio controlled aircraft. This code is meant to serve as a minimum guideline to all participants. It is understood that the ultimate responsibility for the safety of any aircraft lies with the owner(s), pilot(s) and spectator(s) involved in any event. It is the responsibility of all participants to exercise caution when operating, or observing the operation of all radio controlled aircraft. The pilot/owner of an aircraft will not be dissuaded from taking whatever steps they deem necessary, in addition to this code, to insure that their aircraft is safe.
- 1.2) The most current AMA Safety Code in effect is to be observed.

Section 3.0: Safety Review

- 3.4) Flight Testing: All aircraft are to have been flight tested and flight trimmed with a minimum of six (6) flights before the model is allowed to fly at an IMAA Sanctioned event.
- 3.5) Proof of Flight: The completing and signing of the Declaration section of the Safety Review form (see Section 3.2) by the pilot (or owner) shall document, as fact, that the noted aircraft has been successfully flight tested and proven airworthy prior to the IMAA event.

Section 4.0: Spotter/Helper

- 4.1) Spotter/Helper Definition: An assistant to aid the pilot during start-up, and taxing onto the runway. The spotter/helper will assist the pilot in completing a safe flight.
- 4.2) Each pilot is required to have a spotter/helper at all IMAA sanctioned events. The event Safety Committee should be prepared to assist those pilots who do not have a spotter/helper to make sure that every registered pilot has the opportunity to fly at a sanctioned event.

Section 5.0: Emergency Engine Shut Off (Kill Switch)

- 5.1) Magneto spark ignition engines must have a coil-grounding switch on the aircraft to stop the engine. This will also prevent accidental starting of the engine. This switch shall be readily available to both pilot and spotter/helper. This switch is to be operated manually and without the use of the Radio System.
- 5.2) Engines with battery powered ignition systems must have a switch to turn off the power from the battery pack to disable the engine from firing. This will also prevent accidental starting of the engine. This switch shall be readily available to both pilot and spotter/helper. This switch shall be operated manually and without the use of the Radio System.
- 5.3) There must also be a means to stop the engine from the transmitter. The most common method is to completely close the carburetor throat using throttle trim, however other methods are acceptable. This requirement applies to all glow/gas ignition engines regardless of size.

Section 6.0: Radio Requirements

- 6.1) All transmitters must be FCC type certified.
- 6.2) FCC Technician or higher-class license required for 6 meter band operation only.

The following recommendations are included in the Safety Code not to police such items, but rather to offer basic suggestions for enhanced safety. It is expected that IMAA members will avail themselves of technological advances as such become available, to promote the safety of all aircraft and participants.

- Servos need to be of a rating capable to handle the loads that the control surfaces impose upon the servos. Standard servos are not recommended for control surfaces. Servos should be rated heavy-duty ounces of torque. For flight critical control functions a minimum of 45 inch/ounces of torque should be considered. This should be considered a minimum for smaller aircraft and higher torque servos are strongly encouraged for larger aircraft. The use of one servo for each aileron and one for each stabilizer half is strongly recommended. Use of dual servos is also recommended on larger aircraft.
- On board batteries should be, at a minimum, 1000 mAh up to 20 lbs., 1200 mAh to 30 lbs., 1800 mAh to 40 lbs., and 2000 mAh over 40 lbs. flying weight. The number and size of servos, size and loads on control surfaces, and added features should be considered as an increase to these minimums. Batteries should be able to sustain power to the onboard radio components for a minimum of one hour total flying time before recharging.

- Dependable, redundant and fail safe battery systems are recommended.
- The use of anti-glitch devices for long leads is recommended.
- There is no maximum engine displacement limit, as it is the position of this body that an under powered aircraft presents a greater danger than an over powered aircraft. However, the selections of engine size relative to airframe strength and power loading mandates good discretionary judgment by the designer and builder. Current AMA maximums for engine displacement are 6.0 cu. in. for two stroke and 9.6 cu. in. for four stroke engines. These maximums apply only to AMA Sanction competition events such as 511, 512, 515 and 520. All non competition events should be sanctioned as Class C events, in which these engine size maximums do not apply.
- Generally, it is recommended that no attempt should be made to fly a radio controlled model aircraft with a gasoline engine in which the model aircraft weight would exceed 12 pounds per cubic inch of engine displacement (under powered), or be less than 5 pounds per cubic inch of engine displacement (overpowered). Example: Using a 3 cu. in. engine, a model would likely be under powered at an aircraft weight greater than 36 pounds. With the same engine, an aircraft weighing less than 15 pounds would likely be overpowered.
- Servo arms and control horns should be rated heavy-duty. Glass filled servo arms and control horns are highly recommended.
- Control surface linkages are listed in order of preference:
 1. Cable system (pull-pull). A tiller bar is highly recommended along with necessary bracing.
 2. Arrow-shaft, fiberglass or aluminum, 1/4" or 5/16" OD. Bracing every six (6) to ten (10) inches is highly recommended.
 3. Tube in tube (Nyrod). Bracing every few inches is highly recommended. Inner tube should be totally enclosed in outer tube.
 4. Hardwood dowel, 3/8" OD. Bracing every six (6) to ten (10) inches is highly recommended.
- Hinges should be rated heavy-duty and manufactured primarily for use in giant-sized aircraft. Homemade and original design hinges are acceptable if determined to be adequate for the intended use.
- Clevis (steel, excluding heavy-duty ball links) and attachment hardware should be heavy-duty 4-40 thread-and-rod type. 2-56 thread size rod is acceptable for some applications (e.g. throttle). Clevises must have lock nuts and sleeve (fuel tubing) or spring keepers.
- Propeller tips should be painted or colored in a visible and contrasting manner to increase the visibility of the propeller tip arc.

CHECK LIST

During the last few moments of preparation your mind may be elsewhere anticipating the excitement of the first flight. Because of this, you may be more likely to overlook certain checks and procedures that should be performed before the model is flown. To help avoid this, a check list is provided to make sure these important areas are not overlooked. Many are covered in the instruction manual, so where appropriate, refer to the manual for complete instructions. Be sure to check the items off as they are completed.

- 1. Fuel proof all areas exposed to fuel or exhaust residue such as the cowl mounting blocks, wing saddle area, etc.
- 2. Check the C.G. according to the measurements provided in the manual.
- 3. Be certain the battery and receiver are securely mounted in the fuse. Simply stuffing them into place with foam rubber is not sufficient.
- 4. Extend your receiver antenna and make sure it has a strain relief inside the fuselage to keep tension off the solder joint inside the receiver.
- 5. Balance your model *laterally* as explained in the instructions.
- 6. Use threadlocking compound to secure critical fasteners such as the set screws that hold the wheel axles to the struts, screws that hold the carburetor arm (if applicable), screw-lock pushrod connectors, etc.
- 7. Add a drop of oil to the axles so the wheels will turn freely.
- 8. Make sure all hinges are **securely** glued in place.
- 9. Reinforce holes for wood screws with thin CA where appropriate (servo mounting screws, cowl mounting screws, etc.).
- 10. Confirm that all controls operate in the correct direction and the throws are set up according to the manual.
- 11. Make sure there are silicone retainers on all the clevises and that all servo arms are secured to the servos with the screws included with your radio.
- 12. Secure connections between servo wires and Y-connectors or servo extensions, and the connection between your battery pack and the on/off switch with vinyl tape, heat shrink tubing or special clips suitable for that purpose.
- 13. Make sure any servo extension cords you may have used do not interfere with other systems (servo arms, pushrods, etc.).
- 14. Secure the pressure tap (if used) to the muffler with high temp RTV silicone, threadlocking compound or J.B. Weld.
- 15. Make sure the fuel lines are connected and are not kinked.
- 16. Balance your propeller (and spare propellers).
- 17. Tighten the propeller nut and spinner.
- 18. Place your name, address, AMA number and telephone number on or inside your model.
- 19. Cycle your receiver battery pack (if necessary) and make sure it is fully charged.
- 20. If you wish to photograph your model, do so before your first flight.
- 21. Range check your radio when you get to the flying field.

FLYING

The Edge 540 1.60 ARF is a great-flying model that flies smoothly and predictably. The Edge does not, however, possess the self-recovery characteristics of a primary R/C trainer and should be flown only by experienced R/C pilots.

Fuel Mixture Adjustments

A fully cowled engine may run at a higher temperature than an un-cowled engine. For this reason, the fuel mixture should be richened so the engine runs at about 200 rpm below peak speed. By running the engine slightly rich, you will help prevent dead-stick landings caused by overheating.

CAUTION (THIS APPLIES TO ALL R/C AIRPLANES): If, while flying, you notice an alarming or unusual sound such as a low-pitched “buzz,” this may indicate control surface flutter. Flutter occurs when a control surface (such as an aileron or elevator) or a flying surface (such as a wing or stab) rapidly vibrates up and down (thus causing the noise). In extreme cases, if not detected **immediately**, flutter can actually cause the control surface to detach or the flying surface to fail, thus causing loss of control followed by an impending crash. The best thing to do when flutter is detected is to slow the model immediately by reducing power, then land as soon as safely possible. Identify which surface fluttered (so the problem may be resolved) by checking all the servo grommets for deterioration or signs of vibration. Make certain all pushrod linkages are secure and free of play. If it fluttered once, under similar circumstances it will probably flutter again unless the problem is fixed. Some things which can cause flutter are; Excessive hinge gap; Not mounting control horns solidly; Poor fit of clevis pin in horn; Side-play of wire pushrods caused by large bends; Excessive free play in servo gears; Insecure servo mounting; and one of the most prevalent causes of flutter; Flying an over-powered model at excessive speeds.

Takeoff

Before you get ready to takeoff, see how the model handles on the ground by doing a few practice runs at **low speeds** on the runway. Hold “up” elevator to keep the tail wheel on the ground. If necessary, adjust the tail wheel so the model will roll straight down the runway. If you need to calm your nerves before the maiden flight, shut the engine down and bring the model back into the pits. Top off the fuel, then check all fasteners and control linkages for peace of mind.

Remember to takeoff into the wind. When you're ready, point the model straight down the runway, hold a bit of up elevator to keep the tail on the ground to maintain tail wheel steering, then gradually advance the throttle. As the

model gains speed decrease up elevator allowing the tail to come off the ground. One of the most important things to remember with a tail dragger is to always be ready to apply **right** rudder to counteract engine torque. Gain as much speed as your runway and flying site will practically allow before gently applying up elevator, lifting the model into the air. At this moment it is likely that you will need to apply more right rudder to counteract engine torque. Be smooth on the elevator stick, allowing the model to establish a **gentle** climb to a safe altitude before turning into the traffic pattern.

Flight

For reassurance and to keep an eye on other traffic, it is a good idea to have an assistant on the flight line with you. Tell him to remind you to throttle back once the plane gets to a comfortable altitude. While full throttle is usually desirable for takeoff, most models fly more smoothly at reduced speeds.

Take it easy with the Edge for the first few flights, gradually getting acquainted with it as you gain confidence. Adjust the trims to maintain straight and level flight. After flying around for a while, and while still at a safe altitude with plenty of fuel, practice slow flight and execute practice landing approaches by reducing the throttle to see how the model handles at slower speeds. Add power to see how she climbs as well. Continue to fly around, executing various maneuvers and making mental notes (or having your assistant write them down) of what trim or C.G. changes may be required to fine tune the model so it flies the way you like. Mind your fuel level, but use this first flight to become familiar with your model before landing.

Landing

To initiate a landing approach, lower the throttle while on the downwind leg. Allow the nose of the model to pitch downward to gradually bleed off altitude. Continue to lose altitude, but maintain airspeed by keeping the nose down as you turn onto the crosswind leg. Make your final turn toward the runway (into the wind) keeping the nose down to maintain airspeed and control. Level the attitude when the model reaches the runway threshold, modulating the throttle as necessary to maintain your glide path and airspeed. If you are going to overshoot, smoothly advance the throttle (always ready on the right rudder to counteract torque) and climb out to make another attempt. When you're ready to make your landing flare and the model is a foot or so off the deck, smoothly increase up elevator until it gently touches down. Once the model is on the runway and has lost flying speed, hold up elevator to place the tail on the ground, regaining tail wheel control.

One final note about flying your model. Have a goal or flight plan in mind for **every** flight. This can be learning a new maneuver(s), improving a maneuver(s) you already know, or learning how the model behaves in certain conditions (such as on high or low rates). This is not necessarily to improve your skills (*though it is never a bad idea!*), but more importantly so you do not surprise yourself by impulsively attempting a maneuver and suddenly finding that you've run out of time, altitude or airspeed. Every maneuver should be deliberate, not impulsive. For example, if you're going to do a loop, check your altitude, mind the wind direction (anticipating rudder corrections that will be required to maintain heading), remember to throttle back at the top, and make certain you are on the desired rates (high/low rates). A flight plan greatly reduces the chances of crashing your model just because of poor planning and impulsive moves. **Remember to think.**

Have a ball!

But always stay in control and fly in a safe manner.

GOOD LUCK AND GREAT FLYING!

3D FLYING

Because of the power to weight ratio on 3D planes, straight and level flight should be at a reduced throttle and full power should only be used when the airplane is "loaded" during a maneuver. Learn to manage the throttle and experiment while in the maneuver. The power needed will depend on the maneuver being performed. C.G. also plays a large role in the 3D capability of models as well. Experiment, but keep in mind that being tail heavy is not always the best way to go.

Propeller thrust and thrust vectoring need to be considered for 3D aerobatics. A large diameter prop with a low pitch will provide a lot of pull for the aircraft but will not offer enough air moving across the tail surfaces (thrust vectoring) for 3D. Due to the large number of factors involved, some experimentation will be necessary to find the right propeller pitch and diameter for your model.

Higher RPM engines such as a .46 two-stroke require a low pitch propeller, and lower RPM motors such as a 1.60 will require a higher pitch propeller. If you feel that the effectiveness of the tail surfaces is not enough, try a smaller propeller with a higher pitch.

Another thing to remember is that maximum control throw is not necessary for all 3D maneuvers. Occasionally, too much throw can place the model too far into a stall causing the model to become uncontrollable. Practice your maneuvers at a higher altitude while you become accustomed to your particular plane's stall characteristics.

WATERFALLS

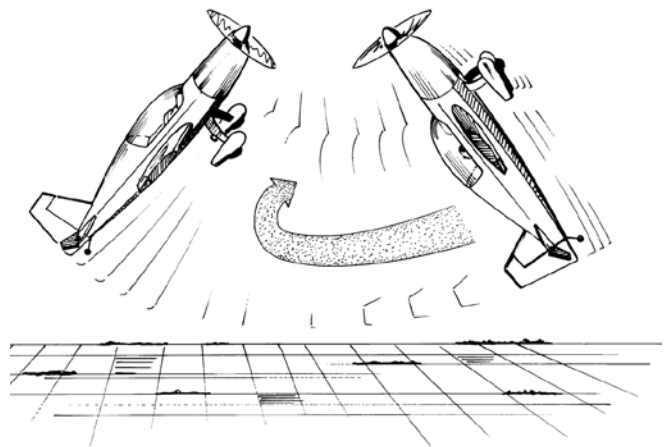

With the model pointing straight up (almost in a hover), push full down elevator and full throttle. As the model rotates and begins to point downwards, reduce the throttle (to keep the model from being pulled downwards). As the model flattens out, add power back in to pull the model around. A lot of models will require a little bit of rudder correction (usually right rudder) during this maneuver. Some planes will require aileron correction to keep the wings level.

UPRIGHT FLAT SPINS

Pull the nose up slightly and slowly decrease power. As the model slows down to a few mph, slowly add in full left rudder and power. Next, start adding in up elevator as needed to keep the model flat in the spin. Most airplanes will require some aileron as well to keep the wings level. This is one of the maneuvers to experiment on; try different C.G. positions and different amounts of throw and power to see how flat the spin will go. It is possible to maintain altitude in the flat spin and in some cases it is also possible to climb during the spin.

INVERTED FLAT SPINS

This is the same as the up-right flat spin except most planes like to spin in the opposite direction, for example: right rudder and down elevator.

THE WALL

Fly straight across the field at a moderate speed and simply pull full up until vertical. Adjust the power as necessary to maintain a hover.

KNIFE EDGE TUMBLE

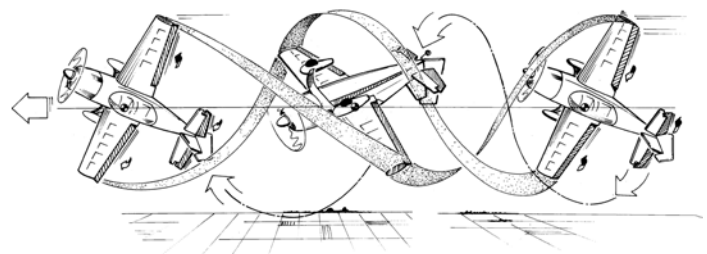

This is an impressive looking maneuver that really isn't as difficult as it looks. (Before learning this maneuver you must

be able to confidently Snap and Tumble your plane and stop the aircraft exactly, without over rotating.) Fly the model Knife Edge from the right at a moderate airspeed, using just enough rudder to maintain Knife Edge, not climbing or diving. Perform one full right negative Tumble by maintaining your rudder setting while applying full throttle, full down elevator, and full right aileron, releasing in time to end again flying Knife Edge to the right. Note that you may need to use some positive elevator and/or left aileron to stop the Tumble at exactly Knife Edge. This maneuver is easier to the right because torque helps stop the Tumble and it can be done at varied airspeeds with proper throttle and rudder modulation.

VERTICAL HOVER

Fly a straight pass across the field at 75ft high and 100ft out and pull the model vertical. Roll the model until the top of it is facing you and slowly begin to reduce power. As the model begins to slow down to 10mph or so, slowly add a little bit of power back in. You will have to adjust the throttle as needed, but make your adjustments smooth. Some right aileron may be needed to keep the model from torque rolling. Use the rudder and elevator to keep the nose pointing straight up. Be patient as this maneuver will take a while to learn.

TORQUE ROLL

This is the same as the vertical hover but without the use of right aileron to keep the model from rolling. If needed, you can use a little left aileron to speed the roll up. As the model rotates around, the controls will appear to be reversed to you but only the orientation of the model has changed.

HARRIER

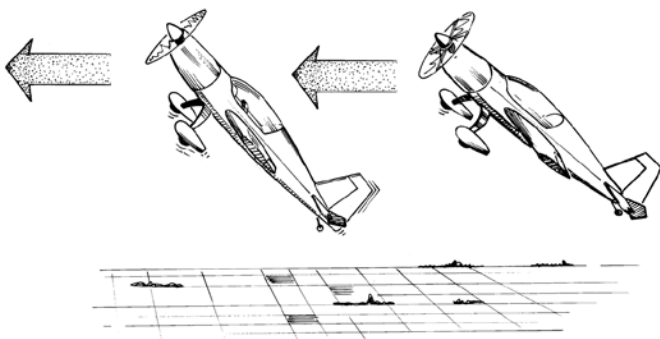

The harrier is nothing more than a high angle of attack flying stall. Check the stall characteristics of your plane before proceeding with this maneuver. Bring your plane across the field at 75 ft high and 100 ft out away from yourself. Slowly pull back on the elevator while reducing throttle. The nose of the plane should come up. Depending on the plane/setup, you may have to make constant aileron (wing walking) and rudder corrections for this maneuver. As the nose of the plane comes up, start adding in a little bit of power to help maintain airspeed. The rudder is now used to turn the model. This maneuver will take some practice as there are a lot of small corrections made to keep most planes in the maneuver.

This is one maneuver where less control is needed. Too much elevator and the model goes into an uncontrollable stall. The C.G. of the plane will have a large effect on the stability of the model during this maneuver. Some planes perform better with more elevator deflection and a farther forward C.G. while other planes prefer a further aft C.G. and less elevator deflection. Elevator to flap mixing can be used on airplanes with marginal wing area, and some planes won't stall so elevator to spoileron mixing will be needed.

ROLLING HARRIER

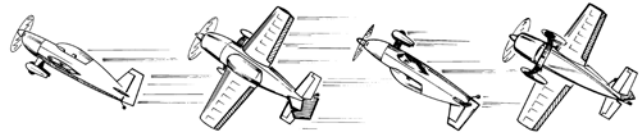

Once you get comfortable with the up-right harrier, it's time to work rolls into the mix. From an up-right harrier, add in left aileron and change from up elevator to down elevator when inverted. If you are comfortable with four point rolls and slow rolls, inputting rudder on the knife edges can improve the maneuver considerably. To turn the model, simply input the elevator or rudder a little sooner or later in the rotation. It's all a matter of timing.

PINWHEEL

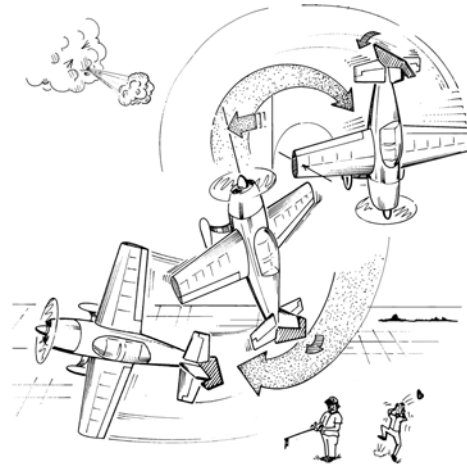

Climb vertically and bring the model to a vertical hover, but do not stop long enough to let the torque pull the model around (climbing or sliding slightly will not be noticeable to spectators but will keep air flowing over the ailerons and provide you roll authority to stop the torque). When the model is hanging, rock the plane left with rudder, then apply full throttle and full right rudder and hold both, completing 3/4s of a VERY tight Knife Edge Loop and flying out Knife Edge. When done correctly, the plane pivots around the wingtip in a very small area. This maneuver can be done either direction.

ENGINE MOUNT TEMPLATES

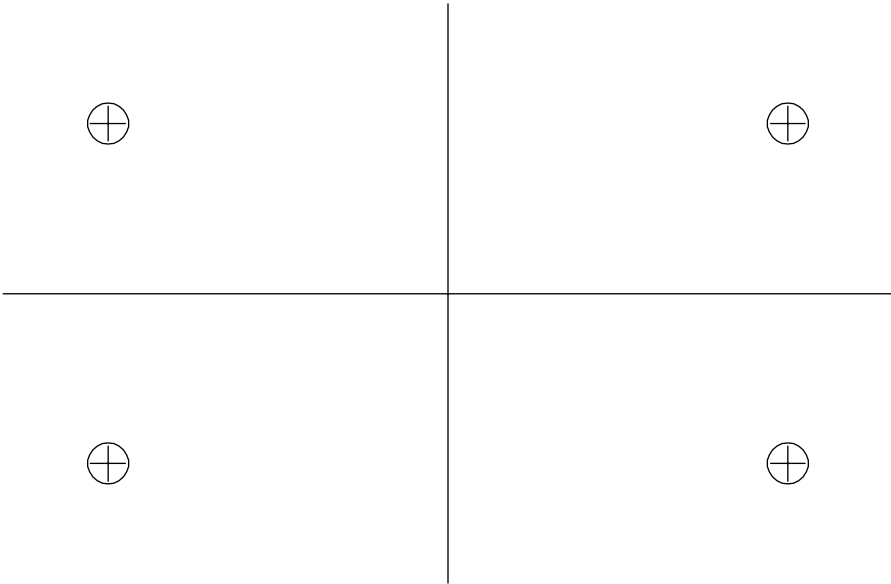

Fuji-Imvac BT-43 EI-2 Engine Mount Template

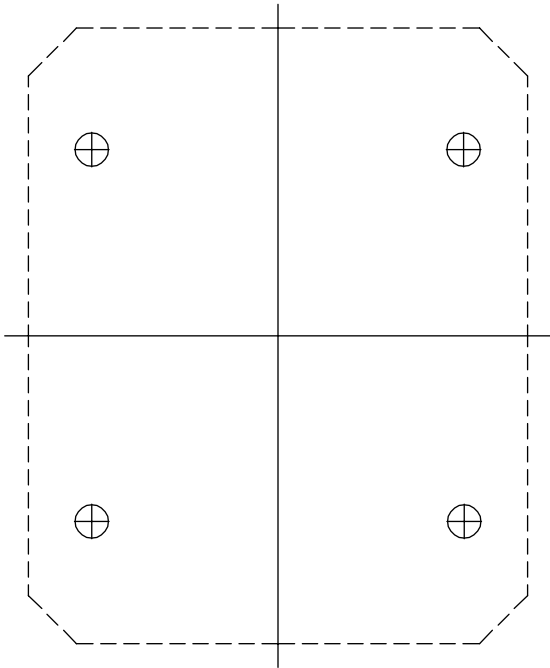

This model belongs to:

Name

Address

City, State Zip

Phone number

AMA number

Great Planes 1.20-1.80 Adjustable Engine Mount Template
(This is also the template for the Great Planes Extra Large Brushless Motor Mount)

ALSO AVAILABLE FROM GREAT PLANES

27% CAP 232 3D ARF
1.60 GLOW / 43 cc GAS **PERFORMANCE SERIES**



Wingspan: 79 in
Wing Area: 1168 in²
Weight RTF: 12.5-14 lb
Wing Loading: 25-27 oz/ft²
Length: 77 in
Requires: 4-6 channel radio w/1 standard and 6 HT servos and a 2-stroke 1.6-1.8 or 4-stroke 1.8-2.1 glow or 32-43cc gasoline engine

*Power. Precision. Polish. The 27% CAP 232 ARF has them all, like the full-size World Aerobatic Competition winner — and they're at your command after only 20-24 hours of easy assembly. For a model of this size, that's the blink of an eye! With short, direct control linkages and oversized control surfaces, it excels at aggressive, IMAC contest-worthy 3D aerobatics as well as traditional sport flying. And, as a Performance Series ARF, the CAP 232 offers the ideal combination of low weight and high strength for incredible aerobatics. The turtle deck is a good example: it's constructed of a precisely sculpted foam shell reinforced with balsa sheeting. MonoKote iron-on covering and a painted fiberglass cowl and wheel pants add to the CAP 232's scale-like looks. Fiberglass composite landing gear complements the model's scale looks with smooth contours and provides the strength needed for confident touchdowns. **GPMA1410***

25% YAK 54 3D ARF
1.60 GLOW / 43 cc GAS **PERFORMANCE SERIES**



Wingspan: 81 in
Wing Area: 1138 in²
Weight: 12.5-15.3 lb
Wing Loading: 25-30 oz/ft²
Length: 68 in
Requires: 4-6 channel radio w/1 standard and 6 HT servos & a 2-stroke 1.6-1.8 or 4-stroke 1.8-2.1 glow or 32-43cc gasoline engine

*It's BIG — and designed for totally “out there” aerobatics! The YAK 54 is a favorite among 3D pilots, and this 25% ARF model captures every nuance of the Unlimited Class competitor. Put yourself at the controls, and experience the thrills of performing precision maneuvers with ease and attitude! The perfect combination of light weight and “in-flight” durability, the YAK 54 is an excellent sport flyer — but also capable of any 3D and IMAC aerobatic maneuver you can think of. A lot of ARFs come with such unreliable hardware that you wouldn't dream of using it, and some don't include hardware at all. But the YAK 54 includes a complete package of well-made hardware that saves you shopping trips and keeps it performing like a champion! **GPMA1411***

38% EXTRA 330S ARF

ALMOST-READY-TO-FLY GIANT-SCALE AEROBAT



Wingspan: 110.5 in
Wing Area: 2279 in²
Weight: 36–38 lb
Wing Loading: 36–38 oz/ft²
Length: 103 in

Requires: 6-channel “mixing” radio w/6-channel Rx and 10 servos; servo synchronizer, 120-150cc 2-cylinder gasoline engine & propeller

*Enjoying the biggest ARF Great Planes has ever made is easier than you'd guess — and it's packed with more extras than you'd ever expect. Despite its wingspan of 110 big, beautiful inches, you can have this giant ready to fly in just 18-20 hours — less time than some ARFs half its size. The performance is perfectly suited for sport or competition, 3D or airshow aerobatics. Such versatility is no surprise: with 4 aileron servos, 3 rudder servos and 2 elevator servos, the 38% Extra 330S has the maneuvering muscle to handle anything! And it's loaded with features and hardware — like a polished spinner and painted fiberglass pilot figure — that are usually expensive extras, but standard equipment with this model! **GPMA1290***

- MonoKote® trim scheme
- Carbon-fiber landing gear
- Carbon-fiber horizontal stabilizer tubes
- Polished aluminum spinner
- Painted fiberglass/carbon-fiber cowl
- Painted fiberglass pilot, wheel pants and gear cuffs.
- Aluminum wing tube
- Aluminum servo arms with ball links and turnbuckle pushrods
- Pull-pull rudder system
- Extensive, high-quality hardware package

O.S. Engines® 1.60 FX Ringed Engine

Weight Without Muffler: 32.6 oz
Practical RPM Range: 1,800-10,000
BHP @ RPM: 3.7 @ 9,000



*The 1.60 FX features dual ball bearings for durability and smooth operation, plus a low crankcase profile that allows for a proportionally taller, semi-squared head - a design refinement that increases cooling fin area and improves heat dispersion. The threaded portion of the crankshaft is extra-long for more secure prop and spinner nut engagement, and the needle valve is remotely mounted for safety during adjustments. The high-speed needle can also be mounted horizontally, vertically, or separate from the engine for more installation options! Both styles include glow plug and 2-year warranty. **OSMG0661***

Fuji-Imvac™ BT-43EI-2 Gasoline Engine w/Electronic Ignition

Displacement: 2.6 cu in (42.5cc)
RPM range: 1200-11,000
Output: 4.2 hp @ 11,000 rpm
Approx. Weight w/muffler: 3.5 lb (1.6kg)
Includes: EIS (Electronic Ignition System), muffler, prop hub, spinner bolt, Champion RCJ6Y spark plug, Walbro HDA222 carb, super lubricating oil
Fuel/Oil Mix: 100-150:1 of regular or high octane gasoline to 2-cycle oil

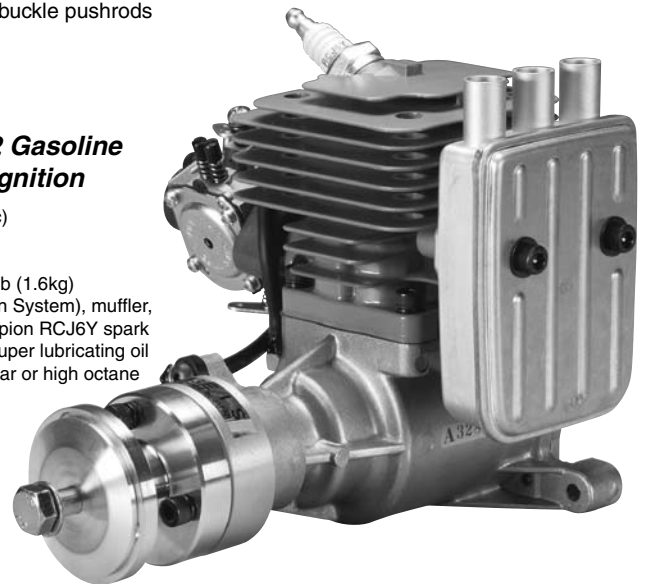

*The design of the BT-43EI-2 reduces size and weight, but delivers an excellent power-to-weight ratio. The innovative back plate lets you bolt the engine directly to the firewall — no mounting plate required! That makes mounting easier, while lowering overall weight and vibration. Three bearings — one front, two center — cut vibration even more, while Fuji-Imvac's popular Electronic Ignition System provides reliable starting in a much smaller size and weight than typical magneto systems. Other features include a Velocity Stack on the Walbro carb to increase air flow and help push fuel into the chamber; a Friction Disk Pad that keeps the prop from slipping on the prop hub; and a spinner bolt predrilled and tapped for attaching a prop adapter. **FJIG0134***

Fuji-Imvac is not related to the original Fuji Engines sold by Meaco.

